

MACHOS

TERRAJAS

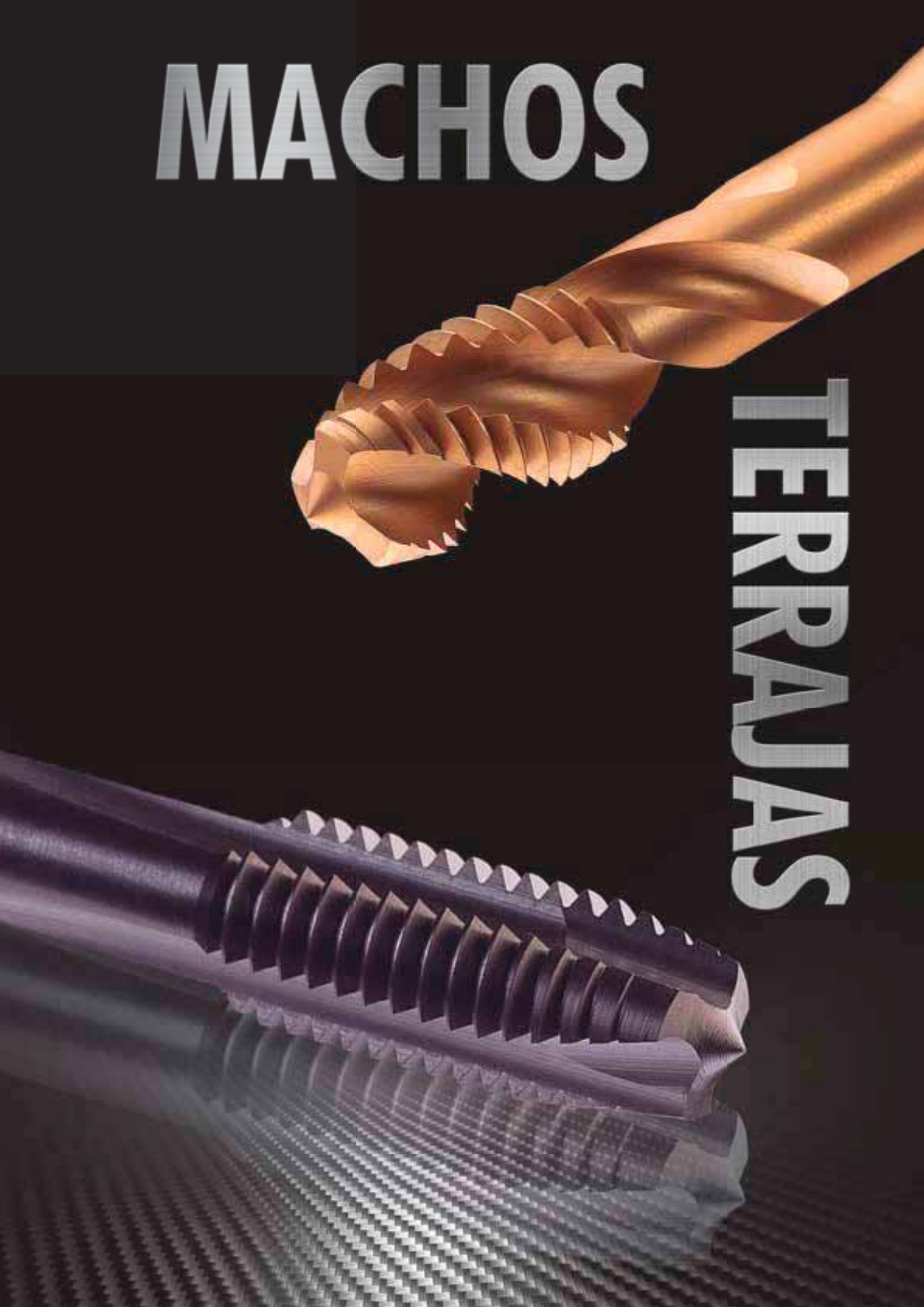

JUEGOS DE MACHOS Y TERRAJAS PARA ROSCAR A MANO HSS

Machos y Terrajas

Verde

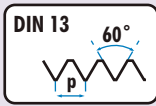

Ref. M0

HSS
DIN 352
DIN 2181
TOL 6H

Ref. C5

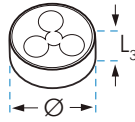
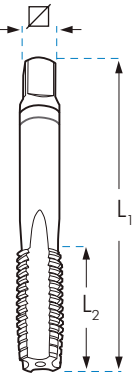
HSS
DIN 223
TOL 6g

		M0				C5			
	Uds.	Ø	L1 x L2 x mm	€	Ø x L3 mm	€			
M 1x0,20	2	0,80	32 x 5,5 x 2,1	75,48					
M 1x0,25	3	0,75	32 x 6,0 x 2,1	75,48	16 x 5	80,70			
M 1,1x0,20	2	0,90	32 x 5,5 x 2,1	75,48					
M 1,1x0,25	3	0,85	32 x 6,0 x 2,1	75,48	16 x 5	79,82			
M 1,2x0,20	2	1,00	32 x 5,5 x 2,1	75,48					
M 1,2x0,25	3	0,95	32 x 6,0 x 2,1	75,48	16 x 5	74,90			
M 1,4x0,20	2	1,20	32 x 7,0 x 2,1	75,48					
M 1,4x0,25	2	1,15	32 x 7,0 x 2,1	75,48					
M 1,4x0,30	3	1,10	32 x 7,0 x 2,1	75,48	16 x 5	68,64			
M 1,6x0,20	2	1,40	32 x 8,0 x 2,1	68,87					
M 1,6x0,25	2	1,35	32 x 8,0 x 2,1	68,87					
M 1,6x0,35	3	1,25	32 x 8,0 x 2,1	68,87	16 x 5	64,85			
M 1,7x0,35	3	1,35	32 x 8,0 x 2,1	64,64	16 x 5	64,85			
M 1,8x0,20	2	1,60	32 x 8,0 x 2,1	64,64					
M 1,8x0,25	2	1,55	32 x 8,0 x 2,1	64,64					
M 1,8x0,35	3	1,45	32 x 8,0 x 2,1	64,64	16 x 5	64,85			
M 2x0,25	2	1,75	36 x 8,0 x 2,1	64,64					
M 2x0,35	2	1,65	36 x 8,0 x 2,1	64,64					
M 2x0,40	3	1,60	36 x 9,0 x 2,1	32,42*	20 x 5	26,77*			
M 2,2x0,45	3	1,75	36 x 9,0 x 2,1	36,81	20 x 5	57,25			
M 2,3x0,40	3	1,90	36 x 9,0 x 2,1	33,97	20 x 5	29,36			
M 2,5x0,45	3	2,05	40 x 9,0 x 2,1	32,61	20 x 5	26,77			
M 2,6x0,45	3	2,10	40 x 9,0 x 2,1	33,02	25 x 9	28,03			
M 3x0,35	2	2,65	40 x 9,0 x 2,7	42,21	20 x 5	42,39			
M 3x0,50	3	2,50	40 x 11,0 x 2,7	18,20*	25 x 9	24,35*			
M 3x0,60	3	2,40	45 x 13,0 x 3,0	37,01	20 x 5	33,22			
M 3,5x0,60	3	2,90	45 x 13,0 x 3,0	21,70	25 x 9	25,48			
M 3,5x0,75	3	2,75	45 x 18,0 x 3,0	40,19	25 x 9	57,29			
M 4x0,50	2	3,50	45 x 13,0 x 3,4	36,50	20 x 5	27,36			
M 4x0,70	3	3,30	45 x 13,0 x 3,4	18,18*	25 x 9	24,47*			
M 4x0,75	3	3,25	45 x 13,0 x 3,4	30,10	20 x 7	37,01			
M 4x0,80	3	3,20	45 x 13,0 x 3,4	119,00	20 x 7	87,49			
M 4,5x0,50	2	4,00	50 x 12,0 x 4,9	35,40	25 x 9	38,10			
M 4,5x0,75	3	3,75	50 x 16,0 x 4,9	32,42	20 x 7	26,78			
M 5x0,50	2	4,50	50 x 12,0 x 4,9	36,33	20 x 5	29,87			
M 5x0,75	2	4,25	50 x 14,0 x 4,9	36,07	20 x 7	37,20			
M 5x0,80	3	4,20	50 x 16,0 x 4,9	19,45*	25 x 9	24,33*			
M 5x0,90	3	4,10	50 x 16,0 x 4,9	34,37	25 x 9	37,20			
M 5x1,00	3	4,00	50 x 16,0 x 4,9	125,65	25 x 9	84,35			
M 5,5x0,90	3	4,60	50 x 16 x 4,9	125,65					
M 6x0,50	2	5,50	50 x 14 x 4,9	26,00					
M 6x0,75	2	5,25	50 x 14 x 4,9	21,95					
M 6x1,00	3	5,00	50 x 19 x 4,9	19,45*					
M 6x1,25	3	4,75	50 x 19 x 4,9	125,65					
M 7x0,75	2	6,25	50 x 14 x 4,9	28,04					
M 7x1,00	3	6,00	50 x 19 x 4,9	23,68*					
M 7x1,25	3	5,75	50 x 19 x 4,9	143,23					
M 8x0,50	2	7,50	50 x 16 x 4,9	44,64					
M 8x0,75	2	7,25	50 x 16 x 4,9	30,20					
M 8x1,00	2	7,00	56 x 18 x 4,9	21,84*					
M 8x1,25	3	6,75	56 x 22 x 4,9	23,66*					
M 8x1,50	3	6,50	56 x 22 x 4,9	139,32					
M 9x1,00	2	8,00	63 x 18 x 5,5	31,13					
M 9x1,25	3	7,80	63 x 22 x 5,5	38,76*					
M 10x0,50	2	9,50	63 x 18 x 5,5	47,30					
M 10x0,75	2	9,25	63 x 18 x 5,5	47,07					
M 10x1,00	2	9,00	63 x 18 x 5,5	23,39					
M 10x1,25	2	8,80	70 x 24 x 5,5	23,71					
M 10x1,50	3	8,50	70 x 24 x 5,5	29,17*					
M 11x0,75	2	10,25	63 x 18 x 6,2	116,50					
M 11x1,00	2	10,00	63 x 18 x 6,2	44,74					
M 11x1,25	2	9,75	63 x 20 x 6,2	44,74					
M 11x1,50	3	9,50	70 x 24 x 6,2	48,62					
M 12x0,75	2	11,25	70 x 20 x 7,0	63,96					
M 12x1,00	2	11,00	70 x 20 x 7,0	41,48					
M 12x1,25	2	10,75	70 x 20 x 7,0	41,35					
M 12x1,50	2	10,50	70 x 20 x 7,0	35,24*					
M 12x1,75	3	10,20	75 x 29 x 7,0	41,06*					
M 13x0,75	2	12,25	70 x 20 x 9,0	116,50					
M 13x1,00	2	12,00	70 x 20 x 9,0	67,72					
M 13x1,25	2	11,75	70 x 20 x 9,0	63,53					
M 13x1,50	2	11,50	70 x 20 x 9,0	63,53					
M 13x1,75	3	11,25	70 x 20 x 9,0	74,20					
M 14x0,75	2	13,25	70 x 20 x 9,0	114,25					
M 14x1,00	2	13,00	70 x 20 x 9,0	62,92					
M 14x1,25	2	12,80	70 x 20 x 9,0	50,49*					
M 14x1,50	2	12,50	70 x 20 x 9,0	39,27					
M 14x1,75	2	12,25	70 x 20 x 9,0	149,93					
M 14x2,00	3	12,00	80 x 30 x 9,0	45,42*					
M 15x1,00	2	14,00	70 x 20 x 9,0	90,57					
M 15x1,25	2	13,75	70 x 20 x 9,0	93,85					
M 15x1,50	2	13,50	70 x 20 x 9,0	83,23					
M 15x2,00	3	13,00	80 x 30 x 9,0	90,78					
M 16x1,00	2	15,00	70 x 20 x 9,0	85,76					
M 16x1,25	2	14,75	70 x 20 x 9,0	90,27					
M 16x1,50	2	14,50	70 x 20 x 9,0	48,86*					
M 16x2,00	3	14,00	80 x 32 x 9,0	64,44*					
M 17x1,00	2	16,00	70 x 20 x 9,0	138,51					
M 17x1,25	2	15,75	70 x 20 x 9,0	138,51					
M 17x1,50	2	15,50	70 x 20 x 9,0	138,51					
M 18x1,00	2	17,00	80 x 22 x 11,0	95,34					
M 18x1,25	2	16,75	80 x 22 x 11,0	132,46					

* Disponibles también con rosca izquierda con 100% de recargo sobre los precios tarifados en rosca derecha
 * Recargo por cojinetes abiertos 20% sobre los precios tarifados

JUEGOS DE MACHOS Y TERRAJAS PARA ROSCAR A MANO HSS

M
MF

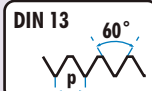

Ref. M0

HSS

DIN
352

DIN
2181



TOL
6H

Ref. C5

HSS

DIN
223

TOL
6g

		M0				C5				M0				C5	
	Uds.	Ø	L1 x L2 x ∇ mm	€	Ø x L3 mm	€		Uds.	Ø	L1 x L2 x ∇ mm	€	Ø x L3 mm	€		
M 18x1,50	2	16,50	80 x 22 x 11,0	64,38	45 x 14	62,85	M 33x3,50	3	29,5	125 x 50 x 20,0	312,17*	65 x 25	117,93*		
M 18x2,00	2	16,00	80 x 22 x 11,0	101,78*	45 x 14	70,23*	M 34x1,50	2	32,5	100 x 25 x 22,0	312,19	65 x 18	131,15		
M 18x2,50	3	15,50	95 x 40 x 11,0	85,04*	45 x 18	51,44*	M 34x2,00	2	32,0	100 x 25 x 22,0	629,42	65 x 18	302,21		
M 19x1,00	2	18,00	80 x 22 x 11,0	201,01	45 x 14	156,00	M 35x1,50	2	33,5	100 x 25 x 22,0	342,49	65 x 18	136,03		
M 19x1,25	2	17,75	80 x 22 x 11,0	201,01	45 x 14	176,43	M 35x2,00	2	33,0	100 x 25 x 22,0	629,42	65 x 18	302,21		
M 19x1,50	2	17,50	80 x 22 x 11,0	201,01	45 x 14	156,00	M 36x1,50	2	34,5	100 x 25 x 22,0	334,38	65 x 18	128,77		
M 19x2,00	2	17,00	80 x 22 x 11,0	238,62	45 x 14	178,22	M 36x2,00	2	34,0	125 x 33 x 22,0	428,62	65 x 18	135,59		
M 20x1,00	2	19,00	80 x 22 x 12,0	126,33	45 x 14	69,81	M 36x3,00	2	33,0	125 x 33 x 22,0	566,10*	65 x 25	145,75*		
M 20x1,25	2	18,75	80 x 22 x 12,0	200,28	45 x 14	157,29	M 36x4,00	3	32,0	150 x 53 x 22,0	398,25*	65 x 25	117,94*		
M 20x1,50	2	18,50	80 x 22 x 12,0	80,62	45 x 14	65,46	M 38x1,50	2	36,5	100 x 25 x 22,0	376,12	75 x 20	198,63		
M 20x2,00	2	18,00	80 x 22 x 12,0	105,93*	45 x 14	69,81*	M 38x2,00	2	36,0	125 x 25 x 22,0	515,43	75 x 20	372,82		
M 20x2,50	3	17,50	95 x 40 x 12,0	95,40*	45 x 18	51,08*	M 39x1,50	2	37,5	110 x 25 x 24,0	497,82	75 x 20	195,71		
M 21x1,00	2	20,00	80 x 22 x 12,0	257,54	45 x 14	191,12	M 39x2,00	2	37,0	125 x 23 x 24,0	497,82	75 x 20	206,67		
M 21x1,25	2	19,75	80 x 22 x 12,0	257,54	45 x 14	191,12	M 39x3,00	2	36,0	125 x 33 x 24,0	480,20*	75 x 30	209,12*		
M 21x1,50	2	19,50	80 x 22 x 12,0	200,48	45 x 14	157,54	M 39x4,00	3	35,0	150 x 53 x 24,0	449,86*	75 x 30	179,39*		
M 22x1,00	2	21,00	80 x 22 x 14,5	141,57	55 x 16	96,63	M 40x1,50	2	38,5	110 x 25 x 24,0	441,69	75 x 20	203,66		
M 22x1,25	2	20,75	80 x 22 x 14,5	198,35	55 x 16	157,48	M 40x2,00	2	38,0	125 x 33 x 24,0	495,24	75 x 20	208,62		
M 22x1,50	2	20,50	80 x 22 x 14,5	88,67	55 x 16	83,13	M 40x3,00	2	37,0	125 x 33 x 24,0	493,43	75 x 30	227,52		
M 22x2,00	2	20,00	80 x 22 x 14,5	141,44*	55 x 16	92,50*	M 42x1,50	2	40,5	110 x 25 x 24,0	488,84	75 x 20	222,29		
M 22x2,50	3	19,50	100 x 40 x 14,5	128,11*	55 x 22	76,08*	M 42x2,00	2	40,0	125 x 33 x 24,0	569,14	75 x 20	304,21		
M 23x1,00	2	22,00	80 x 22 x 14,5	259,78	55 x 16	206,72	M 42x3,00	2	39,0	125 x 33 x 24,0	571,59	75 x 30	222,29		
M 23x1,50	2	21,50	80 x 22 x 14,5	258,77	55 x 16	191,12	M 42x4,50	3	37,5	150 x 53 x 24,0	557,55	75 x 30	182,85		
M 24x1,00	2	23,00	90 x 22 x 14,5	155,48	55 x 16	93,37	M 45x1,50	2	43,5	110 x 25 x 29,0	533,95	90 x 22	267,10		
M 24x1,25	2	22,75	90 x 22 x 14,5	254,11	55 x 16	158,97	M 45x2,00	2	43,0	125 x 33 x 29,0	683,50	90 x 22	313,64		
M 24x1,50	2	22,50	90 x 22 x 14,5	113,04	55 x 16	83,91	M 45x3,00	2	42,0	125 x 33 x 29,0	683,50	90 x 36	327,24		
M 24x2,00	2	22,00	90 x 22 x 14,5	164,14*	55 x 16	93,37*	M 45x4,50	3	40,5	160 x 60 x 29,0	643,65	90 x 36	283,34		
M 24x3,00	3	21,00	110 x 50 x 14,5	151,57*	55 x 22	76,08*	M 48x1,50	2	46,5	140 x 33 x 29,0	596,12	90 x 22	282,33		
M 25x1,00	2	24,00	90 x 22 x 14,5	221,42	55 x 16	143,03	M 48x2,00	2	46,0	140 x 33 x 29,0	893,29	90 x 22	288,62		
M 25x1,25	2	23,75	90 x 22 x 14,5	370,42	55 x 16	239,25	M 48x3,00	2	45,0	140 x 33 x 29,0	828,27	90 x 36	301,40		
M 25x1,50	2	23,50	90 x 22 x 14,5	203,31	55 x 16	121,89	M 48x5,00	3	43,0	180 x 65 x 29,0	774,96	90 x 36	283,68		
M 25x2,00	2	23,00	90 x 22 x 14,5	377,64	55 x 16	232,62	M 50x1,50	2	48,5	140 x 33 x 29,0	651,93	90 x 22	269,62		
M 26x1,00	2	25,00	90 x 22 x 14,5	197,94	55 x 16	207,21	M 50x3,00	2	57,0	140 x 33 x 29,0	878,60	90 x 22	299,45		
M 26x1,50	2	24,50	90 x 22 x 14,5	185,71	55 x 16	114,30	M 52x1,50	2	50,5	140 x 33 x 32,0	690,12	90 x 22	280,57		
M 26x2,00	2	24,00	90 x 22 x 14,5	217,90	55 x 16	205,44	M 52x2,00	2	50,0	140 x 33 x 32,0	1.001,30	90 x 22	326,06		
M 27x1,00	2	26,00	90 x 22 x 16,0	217,92	65 x 18	137,94	M 52x3,00	2	49,0	140 x 33 x 32,0	921,88	90 x 36	355,82		
M 27x1,50	2	25,50	90 x 22 x 16,0	204,77	65 x 18	126,88	M 52x5,00	3	47,0	180 x 65 x 32,0	936,69	90 x 36	283,68		
M 27x2,00	2	25,00	90 x 22 x 16,0	227,48*	65 x 18	137,99*	M 56x4,00	2	52,0	180 x 47 x 32,0	1.027,96	105 x 36			
M 27x3,00	3	24,00	110 x 50 x 16,0	193,23*	65 x 25	113,22*	M 56x5,50	3	50,5	200 x 85 x 35,0	1.541,95	105 x 36			
M 28x1,00	2	27,00	90 x 22 x 16,0	367,79	65 x 18	209,42	M 60x5,50	3	54,5	200 x 85 x 35,0	1.929,85	105 x 36			
M 28x1,50	2	26,50	90 x 22 x 16,0	206,30	65 x 18	126,88	M 64x4,00	2	60,0	180 x 50 x 35,0	1.900,14	120 x 36			
M 28x2,00	2	26,00	90 x 22 x 16,0	242,22	65 x 18	207,38	M 64x6,00	3	58,0	220 x 90 x 39,0	2.346,35	120 x 36			
M 30x1,00	2	29,00	90 x 22 x 18,0	229,10	65 x 18	146,18	M 68x6,00	3	62,0	220 x 90 x 39,0	2.809,03	120 x 36			
M 30x1,50	2	28,50	90 x 22 x 18,0	213,97	65 x 18	126,87	M 72x6,00	3	66,0	235 x 90 x 39,0	3.043,27				
M 30x2,00	2	28,00	90 x 22 x 18,0	246,68	65 x 18	140,61	COJINETES CON MEDIDA EXTERIOR EN PULGADAS								
M 30x3,00	2	27,00	125 x 56 x 18,0	247,79*	65 x 25	197,16*						C5			
M 30x3,50	3	26,50	125 x 50 x 18,0	248,69*	65 x 25	113,51*						€			
M 32x1,00	2	31,00	90 x 22 x 18,0	495,65	65 x 18	225,98						Ø x L3 mm			
M 32x1,50	2	30,50	90 x 22 x 18,0	254,77	65 x 18	132,83						€			
M 32x2,00	2	30,00	90 x 22 x 18,0	374,71	65 x 18	207,46	M 3x0,50	25,4 x 9	22,54	M 8x1,25	38,1 x 9	23,92			
M 33x1,00	2	32,00	100 x 25 x 20,0	482,14	65 x 18	237,02	M 4x0,70	25,4 x 9	22,54	M10x1,50	25,4 x 9	30,27			
M 33x1,50	2	31,50	100 x 25 x 20,0	272,48	65 x 18	125,69	M 5x0,80	25,4 x 9	22,96	M10x1,50	38,1 x 10	30,27			
M 33x2,00	2	31,00	100 x 25 x 20,0	344,02	65 x 18	136,88	M 6x1,00	25,4 x 9	22,54	M12x1,75	25,4 x 9	36,48			
M 33x3,00	2	30,00	125 x 56 x 20,0	446,04*	65 x 25	250,43	M 8x1,25	25,4 x 9	23,92	M12x1,75	38,1 x 14	36,48			

* Disponibles también con rosca izquierda con 100% de recargo sobre los precios tarifados en rosca derecha
* Recargo por cojinetes abiertos 20% sobre los precios tarifados

JUEGOS DE MACHOS Y TERRAJAS PARA ROSCAR A MANO HSS

 Machos y Terrajas
 Verde

UNC

Ref. M0

HSS

DIN 351

TOL 2B

Ref. C5

HSS

DIN 223

TOL 2a

UNF

Ref. M0

HSS

DIN 2181

TOL 2B

Ref. C5

HSS

DIN 223

TOL 2a

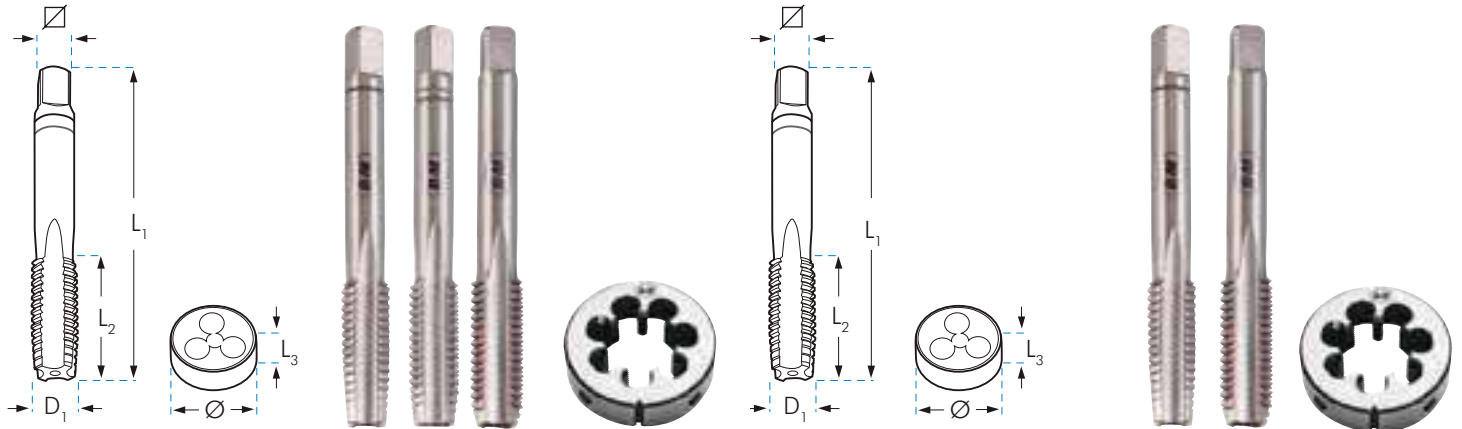

Machos	Uds.	D1 mm	L1 x L2 x D1 mm	M0		C5		Machos	Uds.	D1 mm	L1 x L2 x D1 mm	M0		C5	
				€	Ø x L3 mm	€	€					Ø x L3 mm	€		
UNC n°1-64h.	3	1,85	1,50	36x8x2,1	86,93	16x5		UNF n°2-64h.	2	2,18	1,85	36x8x2,1	56,73		
UNC n°2-56h.	3	2,18	1,80	36x9x2,1	61,43	16x5		UNF n°3-56h.	2	2,51	2,15	40x9x2,1	56,73		
UNC n°3-48h.	3	2,51	2,10	40x9x2,1	61,43	16x5		UNF n°4-48h.	2	2,84	2,35	40x9x2,7	35,35	20x5	36,56
UNC n°4-40h.	3	2,84	2,25	40x11x2,7	47,41	20x5	35,18	UNF n°5-44h.	2	3,17	2,70	45x10x2,7	35,35	20x5	35,27
UNC n°5-40h.	3	3,17	2,60	40x11x2,7	45,32	20x5	35,27	UNF n°6-40h.	2	3,50	2,95	45x16x3,0	33,78	20x5	35,27
UNC n°6-32h.	3	3,50	2,75	45x13x3,0	45,32	20x7	35,27	UNF n°8-36h.	2	4,17	3,50	50x12x3,4	33,78	20x7	35,27
UNC n°8-32h.	3	4,17	3,50	45x13x3,4	45,32	20x7	35,27	UNF n°10-32h.	2	4,83	4,10	50x12x4,9	33,78	20x7	35,27
UNC n°10-24h.	3	4,83	3,90	50x16x4,9	45,32	20x7	35,27	UNF n°12-28h.	2	5,49	4,60	50x12x4,9	35,35	20x7	35,27
UNC n°12-24h.	3	5,49	4,50	50x19x4,9	45,32	20x7	35,27	UNF 1/4-28h.	2	6,35	5,50	50x14x4,9	25,78*	25x9	31,14*
UNC 1/4-20h.	3	6,35	5,10	50x19x4,9	38,84*	20x7	33,24*	UNF 5/16-24h.	2	7,94	6,90	56x22x4,9	27,60*	25x9	34,76*
UNC 5/16-18h.	3	7,94	6,60	56x22x4,9	44,10*	25x9	34,11*	UNF 3/8-24h.	2	9,52	8,50	63x20x5,5	31,87*	38x10	47,42*
UNC 3/8-16h.	3	9,52	8,00	70x24x5,5	50,17*	30x11	47,42*	UNF 7/16-20h.	2	11,11	9,90	63x20x6,2	42,30	38x10	46,53
UNC 7/16-14h.	3	11,11	9,40	70x24x6,2	65,33	38x14	47,42	UNF 1/2-20h.	2	12,70	11,50	70x22x7,0	43,27*	38x10	50,69*
UNC 1/2-13h.	3	12,70	10,75	75x29x7,0	75,17*	38x14	48,75*	UNF 9/16-18h.	2	14,29	12,90	70x22x9,0	56,39	38x10	53,07
UNC 9/16-12h.	3	14,28	12,20	80x30x9,0	88,74	38x14	51,02	UNF 5/8-18h.	2	15,87	14,50	70x22x9,0	72,84*	45x14	69,16*
UNC 5/8-11h.	3	15,87	13,50	80x32x9,0	122,38*	45x18	69,16*	UNF 3/4-16h.	2	19,05	17,50	80x22x11,0	97,84*	45x14	69,16*
UNC 3/4-10h.	3	19,05	16,50	95x40x11,0	166,75*	45x18	69,16*	UNF 7/8-14h.	2	22,22	20,40	80x22x14,5	125,74*	55x16	92,83*
UNC 7/8-9h.	3	22,22	19,50	100x40x14,5	205,28	55x22	96,56	UNF 1"-12h.	2	25,40	23,25	90x22x16,0	166,73	55x16	92,83
UNC 1"-8h.	3	25,40	22,25	110x50x14,5	277,19*	55x22	92,83*	UNS 1"-14h.	2	25,40	23,60	90x22x14,5	181,24*	55x16	100,87*
UNC 1.1/8-7h.	3	28,57	25,00	125x56x18,0	417,94	65x25	137,90	UNF 1.1/8-12h.	2	28,57	26,50	90x22x18,0	237,05	65x18	108,90
UNC 1.1/4-7h.	3	31,75	28,00	125x56x18,0	526,06	65x25	137,90	UNF 1.1/4-12h.	2	31,75	29,50	90x22x20,0	289,50	65x18	143,42
UNC 1.3/8-6h.	3	34,92	30,75	150x63x22,0	667,37	65x25	137,90	UNF 1.3/8-12h.	2	34,92	32,80	125x35x22,0	405,45	65x18	150,14
UNC 1.1/2-6h.	3	38,10	34,00	150x63x24,0	819,40	75x30	215,01	UNF 1.1/2-12h.	2	38,10	36,00	125x40x22,0	512,22	75x20	215,01
UNC 2"-4,5h.	3	50,80	45,00	180x75x32,0	1764,92	90x36		UNF 2"-12h.	2	50,80	48,38	140x40x29,0	1.267,44	90x22	

* Disponibles también con rosca izquierda con 100% de recargo sobre los precios tarifados en rosca derecha

JUEGOS DE MACHOS Y TERRAJAS PARA ROSCAR A MANO HSS



Icon	Uds.	D1 mm	L1 x L2 x mm	M0		C5		Icon	Uds.	M0T		C5T		M0X		C5X	
				HSS	€	HSS	€			HSS	€	HSS	€	HSSCo	OX	€	HSSCo
G 1/8-28h.	2	9,73	8,80	63 x 20 x 5,5	29,62*	38 x 10	42,41*	G 1/8-28 h.	2	65,05	83,53	74,74	86,02				
G 1/4-19h.	2	13,16	11,80	70 x 22 x 9,0	41,74*	38 x 10	42,18*	G 1/4-19 h.	2	118,36	86,45	134,32	86,25				
G 3/8-19h.	2	16,66	15,25	70 x 22 x 9,0	52,40*	45 x 14	55,87*	G 3/8-19 h.	2	144,40	97,25	166,86	92,34				
G 1/2-14h.	2	20,95	19,00	80 x 22 x 12,0	73,49*	45 x 14	55,87*	G 1/2-14 h.	2	203,52	110,08	225,13	116,78				
G 5/8-14h.	2	22,91	21,00	80 x 22 x 14,5	94,03*	55 x 16	77,50*										
G 3/4-14h.	2	26,44	24,50	90 x 22 x 16,0	114,71*	55 x 16	97,18*	G 3/4-14 h.	2	267,00	179,34	323,15	191,00				
G 7/8-14h.	2	30,20	28,25	90 x 22 x 18,0	154,43	65 x 18	120,10										
G 1"-11h.	2	33,25	30,75	100 x 25 x 20,0	181,86*	65 x 18	121,26*	G 1" -11 h.	2	465,35	239,56	531,51	277,62				
G 1.1/8-11h.	2	37,90	35,50	125 x 40 x 22,0	282,45	75 x 20	171,14										
G 1.1/4-11h.	2	41,91	39,50	125 x 40 x 24,0	307,80*	75 x 20	168,00										
G 1.3/8-11h.	2	44,32	42,00	125 x 40 x 29,0	418,06	90 x 22	270,50										
G 1.1/2-11h.	2	47,80	45,25	140 x 40 x 29,0	465,17	90 x 22	260,58										
G 1.3/4-11h.	2	53,75	51,25	140 x 40 x 32,0	773,33	105 x 22	270,50										
G 2"-11h.	2	59,61	57,00	160 x 40 x 35,0	859,89	105 x 22	325,55										
G 2.1/4-11h.	2	65,71	63,00	160 x 40 x 39,0	1.473,05	105 x 22											
G 2.1/2-11h.	2	75,18	72,50	160 x 40 x 39,0	2.214,16	120 x 22											
G 2.3/4-11h.	2	81,53	79,00	160 x 40 x 39,0	2.684,88	135 x 22											
G 3"-11h.	2	87,88	85,50	160 x 40 x 39,0	2.794,41	130 x 25											
G 4"-11h.	2	113,03	110,50	180 x 45 x 44,0	4.238,17												



M0-3B						
Icon	Uds.	D1 mm	L1 x L2 x mm	€		
UNF n°4-48-3B	2	2,84	2,35	40x9x2,7	45,02	
UNF n°5-44-3B	2	3,17	2,70	45x10x2,7	45,02	
UNF n°6-40-3B	2	3,50	2,95	45x16x3,0	43,02	
UNF n°10-32-3B	2	4,83	4,10	50x12x4,9	43,02	
UNF n°12-28-3B	2	5,49	4,60	50x12x4,9	45,02	
UNF 1/4-28-3B	2	6,35	5,50	50x14x4,9	32,83	
UNF 5/16-24-3B	2	7,94	6,90	56x22x4,9	35,15	
UNF 3/8-24-3B	2	9,52	8,50	63x20x5,5	40,58	
UNF 7/16-20-3B	2	11,11	9,90	63x20x6,2	53,88	
UNF 1/2-20-3B	2	12,70	11,50	70x22x7,0	55,11	

* Disponibles también con rosca izquierda con 100% de recargo sobre los precios tarifados en rosca derecha

Machos y Terrajas
Verde Rosa

JUEGOS DE MACHOS Y TERRAJAS PARA ROSCAR A MANO HSS

BSW

Ref. M0

HSS DIN 351 TOL Clase 2

Ref. C5

HSS DIN 223

DIN BS84 55°

BSF

Ref. M0

HSS DIN 5157 TOL ISO 228

Ref. C5

HSS DIN 223

DIN BS84 55°

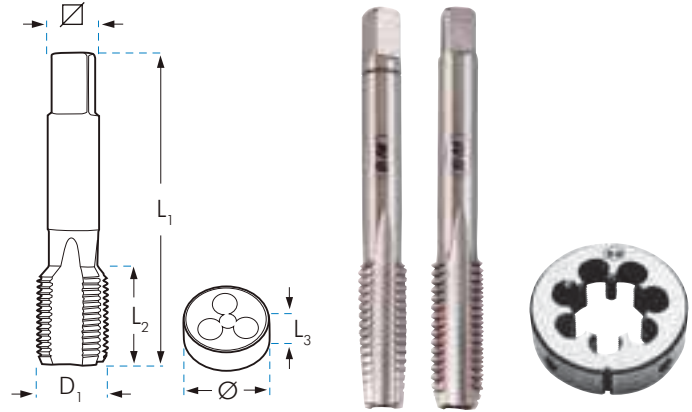
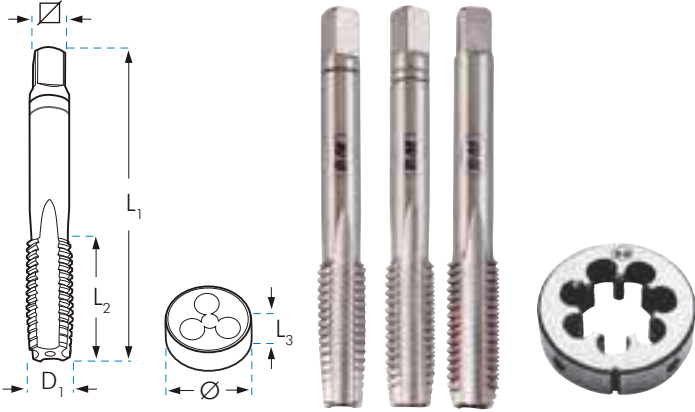

		M0				C5	
	Uds.	D1 mm	$L_1 \times L_2 \times \nabla$ mm	€	$\emptyset \times L_3$ mm	€	
W 1/16-60h.	3	1,59	1,15 32x8x2,1	48,70	16x5	65,54	
W 3/32-48h.	3	2,38	1,80 40x9x2,1	35,61	20x5	33,82	
W 1/8-40h.	3	3,17	2,55 40x14x2,7	25,58*	25x9	26,69*	
W 5/32-32h.	3	3,97	3,10 45x17x3,4	25,84	25x9	26,72	
W 3/16-24h.	3	4,76	3,60 50x19x4,9	25,58	25x9	26,69	
W 7/32-24h.	3	5,55	4,40 50x19x4,9	42,07	25x9	34,86	
W 1/4-20h.	3	6,35	5,10 50x20x4,9	28,81*	25x9	26,72*	
W 5/16-18h.	3	7,94	6,50 56x20x4,9	35,19*	25x9	27,87*	
W 3/8-16h.	3	9,52	7,90 63x22x5,5	38,66*	38x10	40,33*	
W 7/16-14h.	3	11,11	9,25 70x22x6,2	51,90	38x10	40,39	
W 1/2-12h.	3	12,70	10,50 75x25x7,0	55,69	38x14	40,38	
W 9/16-12h.	3	14,29	12,00 80x26x9,0	75,76	38x14	48,40	
W 5/8-11h.	3	15,87	13,40 80x27x9,0	87,12*	45x18	58,65*	
W 11/16-11h.	3	17,46	15,25 95x32x11,0	201,47	45x18	94,80	
W 3/4-10h.	3	19,05	16,50 95x32x11,0	124,02*	45x18	58,74*	
W 7/8-9h.	3	22,22	19,25 100x32x14,5	169,38*	55x22	86,37*	
W 1" - 8h.	3	25,40	21,75 110x36x14,5	207,57*	55x22	87,15*	
W 1.1/8-7h.	3	28,57	24,75 125x40x18,0	307,66	65x25	137,24	
W 1.1/4-7h.	3	31,75	27,75 125x40x18,0	372,24	65x25	137,29	
W 1.3/8-6h.	3	34,92	30,50 150x50x22,0	462,90	65x25	139,82	
W 1.1/2-6h.	3	38,10	33,50 150x50x24,0	557,31	75x30	212,54	
W 1.5/8-5h.	3	41,27	46,50 150x56x24,0	761,22	75x30	259,71	
W 1.3/4-5h.	3	44,45	39,00 160x58x29,0	936,89	90x36	326,85	
W 1.7/8-4,5h.	3	47,62	42,00 180x65x29,0	1.210,05	90x36	357,64	
W 2" - 4,5h.	3	50,80	44,50 180x65x32,0	1.270,34	90x36	374,82	
W 2.1/4-4h.	3	57,15	50,00 200x85x35,0	2.104,90	105x36		
W 2.1/2-4h.	3	63,50	56,50 220x85x39,0	2.560,65	120x36		
W 2.3/4-3,5h.	3	69,85	62,00 250x90x44,0	3.656,30	120x36		
W 3" - 3,5h.	3	76,20	68,00 250x90x44,0	4.229,93	140x36		

		M0				C5	
	Uds.	D1 mm	$L_1 \times L_2 \times \nabla$ mm	€	$\emptyset \times L_3$ mm	€	
BSF 3/16-32h.	2	4,76	4,0 50x19x4,9	96,25	20x7	34,46	
BSF 1/4-26h.	2	6,35	5,2 50x20x4,9	39,15	20x7	38,17	
BSF 5/16-22h.	2	7,94	6,6 56x20x4,9	45,65	25x9	38,59	
BSF 3/8-20h.	2	9,52	8,1 63x22x5,5	52,82	30x11	74,14	
BSF 7/16-18h.	2	11,11	9,5 70x22x6,2	63,39	30x11	73,46	
BSF 1/2-16h.	2	12,70	11,0 75x25x7,0	71,72	38x10	64,10	
BSF 9/16-16h.	2	14,29	12,5 80x26x9,0	85,96	38x10	67,65	
BSF 5/8-14h.	2	15,88	14,0 80x26x9,0	112,49	45x14	105,46	
BSF 3/4-12h.	2	19,05	16,5 95x33x11,0	171,95	45x14	106,43	
BSF 7/8-11h.	2	22,23	19,5 100x33x14,5	205,23	55x22	142,73	
BSF 1" - 10h.	2	25,40	22,5 110x40x14,5	288,08	55x22	141,15	
BSF 1.1/8-9h.	2	28,57	25,5 110x40x16,0	650,02			
BSF 1.1/4-9h.	2	31,75	28,5 125x46x18,0	742,13			
BSF 1.1/2-8h.	2	38,10	34,5 150x55x22,0	1.131,04			

INOX

		M0T		C5T	
	Uds.	$L_1 \times L_2 \times \nabla$ mm	€	$\emptyset \times L_3$ mm	€
W 3/16-24 h.	3	50 x 19 x 4,90	48,83	25x9	48,81
W 1/4-20 h.	3	50 x 20 x 4,90	54,66	25x9	49,70
W 5/16-18 h.	3	56 x 20 x 4,90	59,89	25x9	51,67
W 3/8-16 h.	3	63 x 22 x 5,50	70,49	38x10	61,08
W 1/2-12 h.	3	75 x 25 x 7,00	99,47	38x14	82,06



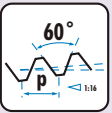

* Disponibles también con rosca izquierda con 100% de recargo sobre los precios tarifados en rosca derecha

MACHOS Y TERRAJAS PARA ROSCAR A MANO HSS

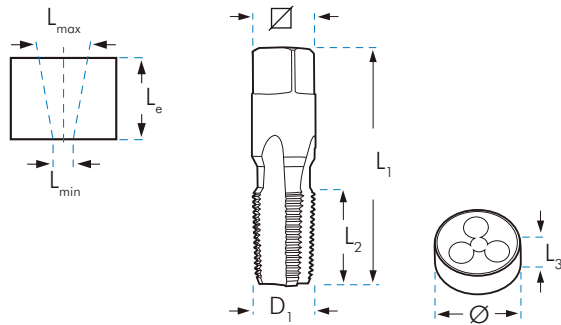
NPTF  Rosca AMERICANA
Rosca Cónica estanca Ref. M0 **HSS** Ref. C5 **HSS** **DIN 223**

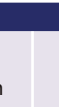

								M0	C5	
		Uds.	D1 mm		Lmin x Lmax mm	Le mm	L1 x L2 x ∇ mm	€	Ø x L3 mm	€
NPTF 1/16-27 h.		1	7,87	6,2	6,00 x 6,41	12,0	54 x 18 x 6,0		25 x 11	
NPTF 1/8-27 h.		1	10,22	8,5	8,30 x 8,76	12,0	54 x 19 x 8,0	78,47	38 x 10	171,36
NPTF 1/4-18 h.		1	13,58	11,0	10,70 x 11,40	17,5	62 x 27 x 11,0	109,98	38 x 15	171,36
NPTF 3/8-18 h.		1	17,02	14,5	14,20 x 14,84	17,6	65 x 27 x 13,0	151,82	45 x 14	223,74
NPTF 1/2-14 h.		1	21,21	17,8	17,40 x 18,33	22,8	80 x 35 x 13,0	212,30	45 x 20	223,74
NPTF 3/4-14 h.		1	26,56	23,0	22,80 x 23,68	23,0	83 x 35 x 17,0	324,51	55 x 22	426,44
NPTF 1"-11,5 h.		1	33,19	29,0	28,60 x 29,72	27,4	95 x 44 x 21,0	432,25	65 x 25	

NPT  Rosca AMERICANA
Rosca Cónica no estanca (Briggs) Ref. M0 **HSS** Ref. C5 **HSS** **DIN 223**

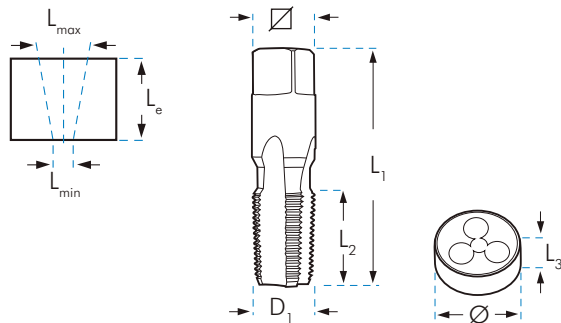



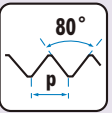

								M0	C5		
		Uds.	D1 mm			Lmin x Lmax mm	Le mm	L1 x L2 x ∇ mm	€	Ø x L3 mm	€
NPT 1/16-27 h.		1	7,89	6,20	EMNPT1/16	6,00 x 6,38	12,0	54 x 18 x 6,0	29,80	25 x 9	96,66
NPT 1/8-27 h.		1	10,24	8,50	EMNPT1/8	8,30 x 8,73	12,0	54 x 19 x 8,0	29,80	30 x 11	72,83
NPT 1/4-18 h.		1	13,62	11,00	EMNPT1/4	10,70 x 11,35	17,5	62 x 27 x 11,0	41,80	38 x 14	72,83
NPT 3/8-18 h.		1	17,05	14,50	EMNPT3/8	14,20 x 14,80	17,6	65 x 27 x 13,0	57,69	45 x 18	95,08
NPT 1/2-14 h.		1	21,23	17,80	EMNPT1/2	17,40 x 18,32	22,8	80 x 35 x 13,0	80,66	45 x 18	95,08
NPT 3/4-14 h.		1	26,57	23,00	-	22,80 x 23,66	23,0	83 x 35 x 17,0	123,32	55 x 22	173,94
NPT 1"-11,5 h.		1	33,23	29,00	-	28,60 x 29,69	27,4	95 x 44 x 21,0	137,34	65 x 25	209,10
NPT 1 1/4-11,5 h.		1	41,98	37,50	-	37,40 x 38,45	28,1	125 x 33 x 24,0	225,18	75 x 26	259,84
NPT 1 1/2-11,5 h.		1	48,05	44,00	-	43,40 x 44,52	28,4	140 x 33 x 29,0	342,17	90 x 27	362,52
NPT 2"-11,5 h.		1	60,09	56,00	-	55,50 x 56,56	28,4	160 x 33 x 35,0	534,19	105 x 36	504,72

* Ver escariador previo pag.125

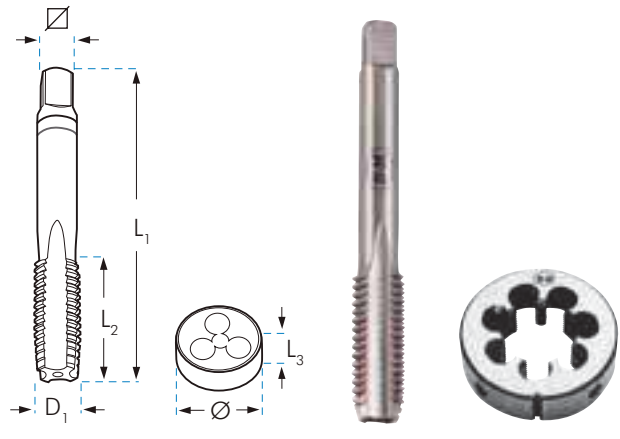
MACHOS Y TERRAJAS PARA ROSCAR A MANO HSS



PG  Ref. M0 **HSS** **DIN 40430** Ref. C5 **HSS** **DIN 223**

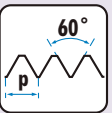

						M0		C5
		Uds.	D1 mm		L1 x L2 x mm	€	Ø x L3 mm	€
Pg 7	20h.	1	12,5	11,50	70x20x7,0	31,57	38x10	61,69
Pg 9	18h.	1	15,2	14,00	70x20x9,0	40,14	38x10	61,69
Pg 11	18h.	1	18,6	17,25	80x22x11,0	55,73	45x14	77,24
Pg 13,5	18h.	1	20,4	19,00	80x22x12,0	61,12	45x14	77,24
Pg 16	18h.	1	22,5	21,25	80x22x14,5	73,40	55x16	99,65
Pg 21	16h.	1	28,3	27,00	90x22x18,0	107,94	65x18	141,64
Pg 29	16h.	1	37,0	35,50	100x25x22,0	214,33	65x18	141,64
Pg 36	16h.	1	47,0	45,50	140x32x29,0	333,87	90x22	363,05
Pg 42	16h.	1	54,0	52,50	140x36x32,0	396,49	105x22	363,05
Pg 48	16h.	1	59,3	58,00	160x36x35,0	500,04	105x22	481,44

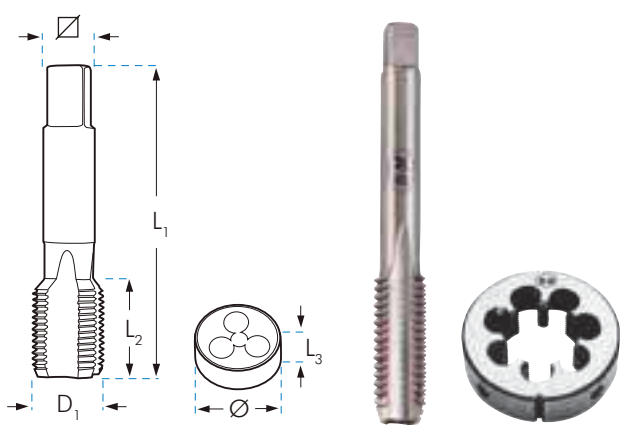

NPSF  Rosca AMERICANA Rosca Cilíndrica estanca Ref. M0 **HSS** Ref. C5 **HSS** **DIN 223**

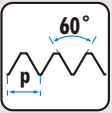

						M0		C5
		Uds.	D1 mm		L1 x L2 x mm	€	Ø x L3 mm	€
NPSF 1/8-27 h.	1	10,05	8,75	63x18x5,5	118,16	38x10	205,85	
NPSF 1/4-18 h.	1	13,35	11,30	70x20x9,0	170,75	38x10	205,85	
NPSF 3/8-18 h.	1	16,78	14,70	70x20x9,0	236,18	45x14	261,86	
NPSF 1/2-14 h.	1	20,87	18,20	80x22x12,0	308,75	45x14	261,86	
NPSF 3/4-14 h.	1	26,23	23,50	90x22x16,0	469,78	55x16	566,03	
NPSF 1"-11,5 h.	1	32,81	29,50	100x25x20,0				

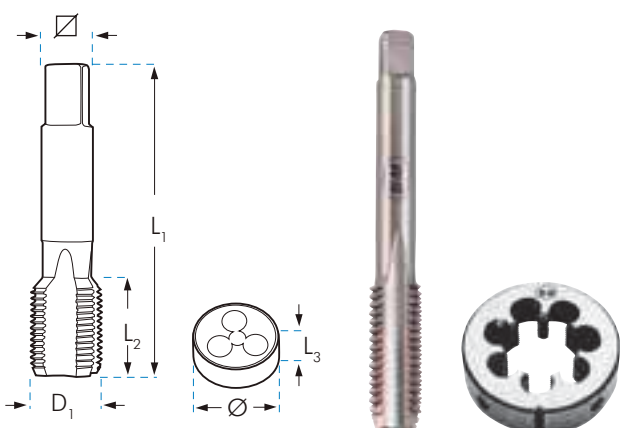
NPS (M)  Rosca AMERICANA Rosca Cilíndrica no estanca Ref. M0 **HSS** Ref. C5 **HSS** **DIN 223**



						M0		C5
		Uds.	D1 mm		L1 x L2 x mm	€	Ø x L3 mm	€
NPS 1/8-27 h.	1	10,20	8,9	63x18x5,5	97,91	38x10	171,50	
NPS 1/4-18 h.	1	13,60	11,7	70x20x9,0	77,92	38x10	171,50	
NPS 3/8-18 h.	1	17,00	15,0	70x20x9,0	107,77	45x14	218,21	
NPS 1/2-14 h.	1	21,20	18,6	80x22x12,0	140,86	45x14	218,21	
NPS 3/4-14 h.	1	26,55	24,0	90x22x16,0	204,56	55x16	432,27	
NPS 1"-11,5 h.	1	33,20	30,0	100x25x20,0	286,02	65x18	424,27	

JUEGOS DE MACHOS Y TERRAJAS PARA ROSCAR A MANO HSS

BSPT

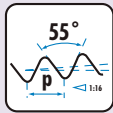

Ref. M0

HSS

DIN 5157

Ref. C5

HSS

DIN 223

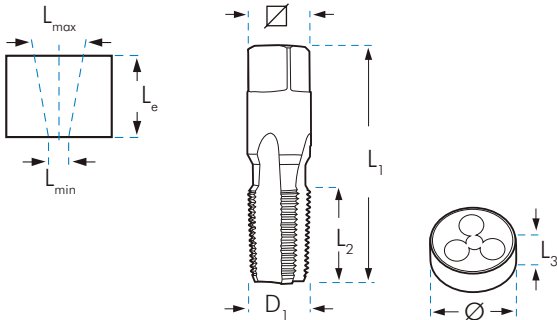

		M0						C5		
		Uds.	D ₁ mm		L _{min} x L _{max} mm	L _e mm	L ₁ x L ₂ x	€	Ø x L ₃ mm	€
BSPT	1/8-28 h.	1	9,73	8,30	8,00 x 8,50	10,1	63 x 15 x 5,5	31,57	30 x 11	99,48
BSPT	1/4-19 h.	1	13,16	11,00	10,70 x 11,35	15,0	79 x 19 x 9,0	44,48	38 x 14	99,48
BSPT	3/8-19 h.	1	16,66	14,50	14,15 x 14,25	15,4	70 x 21 x 9,0	61,78	45 x 16	129,56
BSPT	1/2-14 h.	1	20,95	18,10	17,60 x 18,50	20,5	80 x 26 x 12,0	86,49	55 x 22	129,56
BSPT	5/8-14 h.	1	22,91	20,00	19,50 x 20,40	22,4	90 x 36 x 14,4	139,56	55 x 19	270,34
BSPT	3/4-14 h.	1	26,44	23,50	23,00 x 24,00	21,8	90 x 28 x 16,0	129,85	55 x 22	244,66
BSPT	7/8-14 h.	1	30,20	27,25	26,65 x 28,75	24,0	100 x 36 x 18,0	275,26	65 x 22	353,19
BSPT	1"-11 h.	1	33,25	29,60	29,00 x 30,20	26,0	100 x 33 x 20,0	223,52	65 x 25	282,53

BA

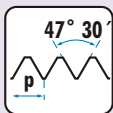

Ref. M0

HSS

DIN 352

Ref. C5

HSS

DIN 223

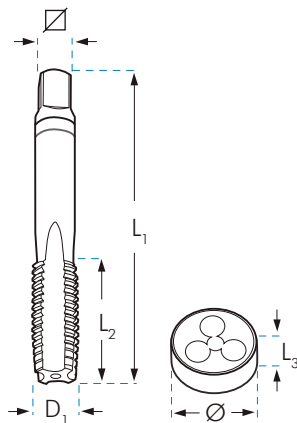

		M0						C5	
		Uds.	D ₁ mm		L ₁ x L ₂ x	€	Ø x L ₃ mm	€	
BA-0		1,00	3	6,0	5,1	50 x 18 x 4,9	172,35	20 x 5	137,29
BA-1		0,90	3	5,3	4,5	50 x 18 x 4,9	172,35	20 x 5	137,29
BA-2		0,81	3	4,7	4,0	50 x 17 x 4,9	172,35	20 x 5	137,29
BA-3		0,73	3	4,1	3,4	45 x 14 x 3,4	185,21	20 x 5	137,29
BA-4		0,66	3	3,6	3,0	45 x 14 x 3,0	185,21	20 x 5	137,29
BA-5		0,59	3	3,2	2,6	45 x 14 x 3,0	221,30	20 x 5	137,29
BA-6		0,53	3	2,8	2,3	40 x 12 x 2,7	221,30	20 x 5	137,29
BA-7		0,48	3	2,5	2,0	40 x 10 x 2,1	243,31	20 x 5	137,29
BA-8		0,43	3	2,2	1,8	36 x 10 x 2,1	243,31	20 x 5	137,29

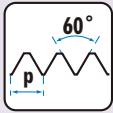
JUEGOS DE MACHOS Y TERRAJAS PARA ROSCAR A MANO HSS
UNx8

Rosca AMERICANA Ref. M0

HSS
**DIN
2181**
**TOL
2B**

Ref. C5

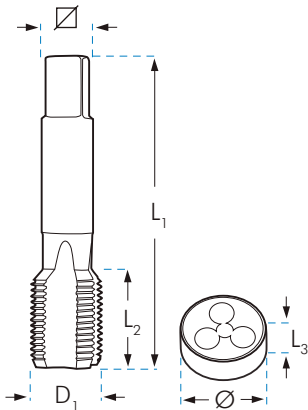
HSS
**DIN
223**
**TOL
2a**

	Uds.	D1 mm	Ø	L1 x L2 x mm	M0		C5	
					€	Ø x L3 mm	€	
UN 1"1/8-8h.	2	28,57	25,40	138x65x17,0	325,01	65x25	362,69	
UN 1"1/4-8h.	2	31,75	28,50	146x65x19,5	421,47	65x25	362,69	
UN 1"3/8-8h.	2	34,92	31,75	154x76x21,0	524,20	65x25	361,10	
UN 1"1/2-8h.	2	38,10	35,00	162x76x23,5	599,90	75x30	408,79	
UN 1"5/8-8h.	2	41,27	38,10	170x80x25,0	745,84	75x30	427,89	
UN 1"3/4-8h.	2	44,45	41,25	178x81x27,0	929,52	90x36	499,21	
UN 1"7/8-8h.	2	47,62	44,45	186x90x29,0	1.159,63	90x36	534,14	
UN 2"-8h.	2	50,80	47,63	194x90x31,5	1.102,47	90x36	499,21	
UN 2"1/4-8h.	2	57,15	54,00	208x90x36,0		120x36		
UN 2"1/2-8h.	2	63,50	60,35	220x100x40		120x36		
UN 2"3/4-8h.	2	69,85	66,70	198x48x39,0		120x36		
UN 3"-8h.	2	76,20	73,05	248x115x49		120x36		

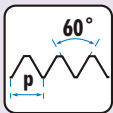
UNEF

Rosca AMERICANA Ref. M0

HSS
**DIN
2181**
**TOL
2B**

Ref. C5

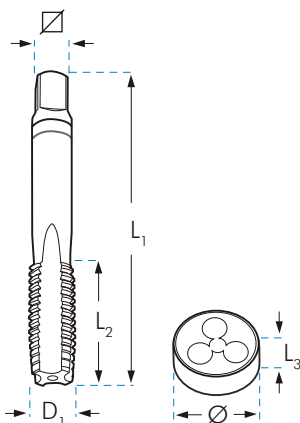
HSS
**DIN
223**
**TOL
2a**

	Uds.	D1 mm	Ø	L1 x L2 x mm	M0		C5	
					€	Ø x L3 mm	€	
UNEF 1/4-32h.	2	6,35	5,55	65x28x4,9	103,06	20x7	102,03	
UNEF 5/16-32h.	2	7,94	7,15	70x30x6,0	115,14	25x9	102,03	
UNEF 3/8-32h.	2	9,52	8,70	75x33x7,0	131,76	30x11	158,42	
UNEF 7/16-28h.	2	11,11	10,20	81x38x6,0	167,73	30x11	158,42	
UNEF 1/2-28h.	2	12,70	11,80	86x44x7,0	189,52	38x10	158,42	
UNEF 9/16-24h.	2	14,29	13,20	92x44x8,0	221,70	38x10	158,42	
UNEF 5/8-24h.	2	15,87	14,80	93x47x9,0	308,59	45x14	253,93	
UNEF 3/4-20h.	2	19,05	17,80	108x52x11,0	456,96	45x14	253,93	
UNEF 7/8-20h.	2	22,22	20,95	120x58x13,0	678,89	55x16	313,43	
UNEF 1"-20h.	2	25,40	24,20	130x65x15,0	653,84	55x16	310,33	

JUEGOS DE MACHOS PARA ROSCAR A MANO APLICACIONES ESPECIALES

1100
N/mm²

Ref. M0MD

HSSCo
5%

OX

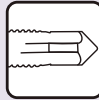

ESPECIAL MATERIALES DUROS (≤ 1100 N/mm²)

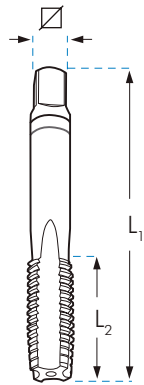

				M0MD
	Uds.		L1 x L2 x \varnothing mm	€
M 3 x 0,50	3	2,50	40 x 11 x 2,7	30,17
M 4 x 0,70	3	3,30	45 x 13 x 3,4	30,17
M 5 x 0,80	3	4,20	50 x 17 x 4,9	31,15
M 6 x 1,00	3	5,00	50 x 19 x 4,9	32,07
M 8 x 1,25	3	6,80	56 x 20 x 4,9	36,46
M 10 x 1,50	3	8,50	70 x 22 x 5,5	46,80
M 12 x 1,75	3	10,20	75 x 24 x 7,0	67,01
M 14 x 2,00	3	12,00	80 x 26 x 9,0	79,32
M 16 x 2,00	3	14,00	80 x 27 x 9,0	105,39
M 18 x 2,50	3	15,50	95 x 30 x 11,0	162,08
M 20 x 2,50	3	17,50	95 x 32 x 12,0	179,95

1400
N/mm²

Ref. M0C

HSS
PM

TiCN



ESPECIAL MATERIALES MUY DUROS (≤ 1400 N/mm²)

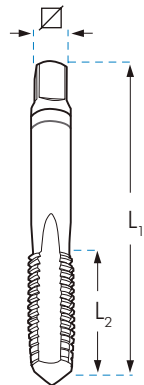

				M0C
	Uds.		L1 x L2 x \varnothing mm	€
M 3 x 0,50	3	2,50	40 x 11 x 2,7	79,39
M 4 x 0,70	3	3,30	45 x 13 x 3,4	85,66
M 5 x 0,80	3	4,20	50 x 17 x 4,9	86,73
M 6 x 1,00	3	5,00	50 x 19 x 4,9	86,73
M 8 x 1,25	3	6,80	56 x 20 x 4,9	97,76
M 10 x 1,50	3	8,50	70 x 22 x 5,5	120,84
M 12 x 1,75	3	10,20	75 x 24 x 7,0	146,90
M 14 x 2,00	3	12,00	80 x 26 x 9,0	180,25
M 16 x 2,00	3	14,00	80 x 27 x 9,0	215,97
M 18 x 2,50	3	15,50	95 x 30 x 11,0	299,43
M 20 x 2,50	3	17,50	95 x 32 x 12,0	329,55

Al

Ref. M0AL

HSS

BRILLANTE



ESPECIAL ALUMINIO

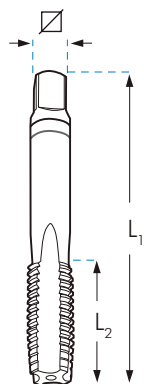

				M0AL
	Uds.		L1 x L2 x \varnothing mm	€
M 3 x 0,50	3	2,50	40 x 11 x 2,7	24,82
M 4 x 0,70	3	3,30	45 x 13 x 3,4	24,10
M 5 x 0,80	3	4,20	50 x 17 x 4,9	25,54
M 6 x 1,00	3	5,00	50 x 19 x 4,9	25,54
M 8 x 1,25	3	6,80	56 x 20 x 4,9	31,35
M 10 x 1,50	3	8,50	70 x 22 x 5,5	38,28
M 12 x 1,75	3	10,20	75 x 24 x 7,0	53,89
M 14 x 2,00	3	12,00	80 x 26 x 9,0	61,93
M 16 x 2,00	3	14,00	80 x 27 x 9,0	87,90
M 18 x 2,50	3	15,50	95 x 30 x 11,0	116,50
M 20 x 2,50	3	17,50	95 x 32 x 12,0	131,33

JUEGOS DE MACHOS Y TERRAJAS PARA ROSCAR A MANO INOXIDABLE

INOX

Ref. MOT
Ref. MOXDIN
352TOL
6H

TiN

Ref. C5T
Ref. C5XDIN
223TOL
6g

OX

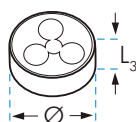
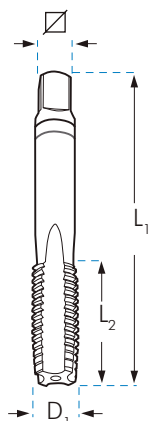



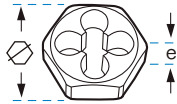

M

	Uds.	L ₁ x L ₂ x ∇ mm	MOT	C5T	MOX	C5X	Ø x L ₃ mm
			HSS TiN €	HSS TiN €	HSSCo OX €	HSSCo OX €	
M 2 x 0,40	3	36 x 9 x 2,10					
M 3 x 0,50	3	40 x 11 x 2,70	35,55	53,25	29,64	37,01	20 x 5
M 4 x 0,70	3	45 x 13 x 3,40	37,35	53,25	29,64	37,01	20 x 5
M 5 x 0,80	3	50 x 16 x 4,90	39,62	53,25	30,85	41,56	20 x 7
M 6 x 1,00	3	50 x 19 x 4,90	39,62	53,25	30,76	42,16	20 x 7
M 8 x 1,00	2	50 x 19 x 4,90	34,83				
M 8 x 1,25	3	56 x 22 x 4,90	45,70	54,59	35,80	45,72	25 x 9
M 10 x 1,00	2	63 x 18 x 5,50	40,19				
M 10 x 1,50	3	70 x 24 x 5,50	60,86	71,67	46,06	58,01	30 x 11
M 12 x 1,50	2	70 x 20 x 7,00	51,17				
M 12 x 1,75	3	75 x 29 x 7,00	70,62	79,47	65,95	61,28	38 x 14
M 14 x 1,50	2	70 x 20 x 9,00	61,45				45 x 18
M 14 x 2,00	3	80 x 30 x 9,00	85,40	79,47	73,04	61,28	
M 16 x 2,00	3	80 x 32 x 9,00	107,24	97,93	100,10	82,28	
M 18 x 2,50	3	95 x 40 x 11,00	132,94		136,71		
M 20 x 2,50	3	95 x 40 x 12,00	137,86		151,74		
M 22 x 2,50	3	100 x 40 x 14,50	174,38				
M 24 x 3,00	3	110 x 50 x 14,50	210,13				

TERRAJAS HEXAGONALES HSS PARA ROSCAR A MANO



M **HSS** **DIN 382**

C5HM			C5HM		
		€			€
M 3 x 0,35	18 x 5	34,46	M 16 x 2,00	41 x 18	94,68
M 3 x 0,50	19 x 5	34,46	M 18 x 1,00	41 x 14	94,68
M 3,5 x 0,60	18 x 5	34,46	M 18 x 1,50	41 x 14	94,68
M 4 x 0,50	18 x 5	34,46	M 18 x 2,50	41 x 18	94,68
M 4 x 0,70	19 x 5	34,46	M 20 x 1,00	41 x 14	94,68
M 5 x 0,50	18 x 5	34,46	M 20 x 1,50	41 x 14	94,68
M 5 x 0,75	18 x 5	34,46	M 20 x 2,00	41 x 18	94,68
M 5 x 0,80	19 x 7	34,46	M 20 x 2,50	41 x 18	94,68
M 6 x 0,75	18 x 7	34,46	M 22 x 1,00	50 x 16	119,71
M 6 x 1,00	19 x 7	34,46	M 22 x 1,50	50 x 16	119,71
M 7 x 0,75	21 x 9	36,62	M 22 x 2,00	50 x 16	119,71
M 7 x 1,00	21 x 9	36,62	M 22 x 2,50	50 x 16	119,71
M 8 x 0,75	21 x 9	36,62	M 24 x 1,00	50 x 16	193,18
M 8 x 1,00	21 x 9	36,62	M 24 x 1,50	50 x 16	193,18
M 8 x 1,25	22 x 9	36,62	M 24 x 2,00	50 x 16	193,18
M 9 x 0,75	21 x 9	43,11	M 24 x 3,00	50 x 22	119,71
M 9 x 1,00	21 x 9	43,11	M 27 x 1,50	60 x 18	161,86
M 9 x 1,25	22 x 9	43,11	M 27 x 2,00	60 x 18	161,86
M 10 x 1,00	27 x 11	43,11	M 27 x 3,00	60 x 25	134,88
M 10 x 1,25	27 x 11	43,11	M 30 x 1,00	60 x 18	161,86
M 10 x 1,50	27 x 11	43,11	M 30 x 1,50	60 x 18	161,86
M 11 x 1,00	27 x 11	71,83	M 30 x 2,00	60 x 18	161,86
M 11 x 1,50	27 x 11	71,83	M 30 x 3,00	60 x 18	161,86
M 12 x 1,25	36 x 10	71,83	M 30 x 3,50	60 x 25	134,88
M 12 x 1,50	36 x 10	71,83	M 33 x 1,50	60 x 18	181,24
M 12 x 1,75	36 x 10	60,35	M 33 x 2,00	60 x 18	181,24
M 14 x 1,25	36 x 14	81,63	M 33 x 3,50	60 x 25	151,03
M 14 x 1,50	36 x 10	81,63	M 35 x 1,50	60 x 18	186,84
M 14 x 2,00	36 x 10	60,35	M 36 x 1,50	60 x 18	186,84
M 15 x 1,00	36 x 14	94,68	M 36 x 2,00	60 x 18	186,84
M 15 x 1,50	41 x 14	94,68	M 36 x 3,00	60 x 18	186,84
M 16 x 1,00	41 x 14	94,68	M 36 x 4,00	60 x 25	155,70
M 16 x 1,50	41 x 14	94,68			

BSP (GAS) **HSS** **DIN 382**

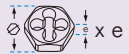
		C5HG
	€	
G 1/8 x 28h.	27 x 11	75,87
G 1/4 x 19h.	36 x 10	75,87
G 3/8 x 19h.	41 x 14	94,88
G 1/2 x 14h.	41 x 14	94,88
G 5/8 x 14h.	50 x 16	223,40
G 3/4 x 14h.	50 x 16	223,40
G 7/8 x 14h.	60 x 18	225,38
G 1" x 11h.	60 x 18	225,38
G1.1/4 x 11h.	70 x 20	300,51
G1.1/2 x 11h.	85 x 22	506,98
G 2" x 11h.	100 x 22	762,89



UNC **HSS** **DIN 382**

		C5HNC
	€	
UNC 1/4-20h	18 x 7	31,42
UNC 5/16-18h	21 x 9	39,10
UNC 3/8-16h	27 x 11	47,20
UNC 7/16-14h	27 x 11	69,65
UNC 1/2-13h	36 x 14	69,91
UNC 9/16-12h	36 x 14	83,54
UNC 5/8-11h	41 x 18	64,73
UNC 3/4-10h	41 x 18	102,96
UNC 7/8-9h	50 x 22	146,11
UNC 1"-8h	50 x 22	146,11
UNC 1.1/8-7h	60 x 25	193,18
UNC 1.1/4-7h	60 x 25	193,18

UNF **HSS** **DIN 382**

		C5HNF
	€	
UNF 1/4-28h.	18 x 7	33,31
UNF 5/16-24h.	21 x 9	41,64
UNF 3/8-24h.	27 x 11	50,10
UNF 7/16-20h.	27 x 11	73,82
UNF 1/2-20h.	36 x 10	74,95
UNF 9/16-18h.	36 x 10	83,54
UNF 5/8-18h.	41 x 14	104,22
UNF 3/4-16h	41 x 14	109,15
UNF 7/8-14h	50 x 16	138,04
UNF 1"-12h	50 x 16	144,71
UNS 1"-14h	50 x 16	144,71
UNF 1.1/8-12h	60 x 18	193,18
UNF 1.1/4-12h	60 x 18	193,18

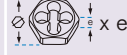
BSW **HSS** **DIN 382**

C5HW			C5HW		
		€			€
BSW 1/8 x 40h.	19 x 5	43,11	BSW 9/16 x 12h.	36 x 14	64,67
BSW 3/16 x 24h.	19 x 7	43,11	BSW 5/8 x 11h.	41 x 18	95,57
BSW 1/4 x 20h.	19 x 7	43,11	BSW 3/4 x 10h.	41 x 18	95,57
BSW 5/16 x 18h.	22 x 9	45,26	BSW 7/8 x 9h.	50 x 22	140,07
BSW 3/8 x 16h.	27 x 11	53,87	BSW 1" x 8h.	50 x 22	140,07
BSW 7/16 x 14h.	27 x 11	53,87	BSW 1.1/8 x 7h.	60 x 25	241,43
BSW 1/2 x 12h.	36 x 14	64,67			

GALGAS PARA LA COMPROBACIÓN DE PASOS DE ROSCAS



	TIPOS DE ROSCA	RANGO DE PASOS		GAM
		Métricos	Ingleses	€
GAM	Pasos rosca métrica	0,25 - 2,5		10,22
GAMW	Pasos rosca métrica /rosca Inglesa	0,25 - 6,0	62h - 4h	17,30

ALARGADOR DE MACHOS

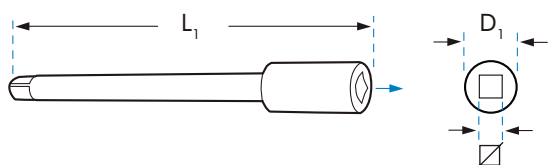
**DIN
377**
DIN 10

	∅ x L1 mm	D1	AL €
AL21	2,1 x 60	6,0	7,11
AL24	2,4 x 70	6,0	7,11
AL27	2,7 x 80	7,0	7,11
AL30	3,0 x 90	7,0	7,11
AL34	3,4 x 95	8,0	7,71
AL38	3,8 x 95	9,0	8,05
AL43	4,3 x 105	10,0	8,96
AL49	4,9 x 110	11,0	8,65
AL55	5,5 x 115	12,0	8,79
AL62	6,2 x 120	14,0	11,00
AL70	7,0 x 125	15,0	11,46
AL80	8,0 x 125	17,0	14,32
AL90	9,0 x 135	19,0	14,70

	∅ x L1 mm	D1	AL €
AL100	10,0 x 140	21,0	20,31
AL110	11,0 x 150	23,0	20,60
AL120	12,0 x 160	25,0	22,18
AL130	13,0 x 165	27,0	34,70
AL145	14,5 x 175	29,0	35,18
AL160	16,0 x 185	30,0	37,22
AL180	18,0 x 195	33,0	42,42
AL200	20,0 x 220	36,0	56,57
AL220	22,0 x 220	40,0	82,68
AL240	24,0 x 235	42,0	101,68
AL260	26,0 x 245	45,0	126,55
AL290	29,0 x 260	55,0	154,26
AL320	32,0 x 280	55,0	201,31

GIRAMACHOS DE ACERO FORJADO

Máxima Resistencia
150 kg/mm²

Ref. GAPRO

DIN 1814

- Cuerpo de Acero Forjado.
- Soporta esfuerzos hasta 150 kg/mm².
- Máxima resistencia y durabilidad.
- Mayor precisión y firmeza en el amarre.
- Su rosca de precisión conforma un conjunto sólido y robusto.
- Maneral antideslizante, mayor agarre en el taller.



GAPRO							
Nº NORMA	Nº 0	Nº 1	Nº 1.1/2	Nº 2	Nº 3	Nº 4	Nº 5
	M1-M8 2,00-5,00	M1-M10 2,00-6,30	M1-M12 2,50-8,00	M4-M12 4,00-9,00	M5-M20 4,90-12,00	M9-M27 5,50-16,00	M13-M32 7,00-20,00
€	17,33	18,31	19,46	24,59	34,80	55,64	117,76

Ref. GA

DIN 1814

- Cuerpo de Aleación de Zinc.
- Alta resistencia y durabilidad.
- Alta precisión y firmeza en el amarre.



GA										
Nº NORMA	Nº 0	Nº 1	Nº 1.1/2	Nº 2	Nº 3	Nº 4	Nº 5	Nº 6	Nº 7	Nº 8
	M1-M8 2,00-5,00	M1-M10 2,00-6,30	M1-M12 2,50-8,00	M4-M12 4,00-9,00	M5-M20 4,90-12,00	M9-M27 5,50-16,00	M13-M32 7,00-20,00	M13-M42 9,00-24,00	M22-M56 16,00-32,00	M33-M64 20,00-35,00
€	14,56	15,39	16,35	20,66	29,24	46,76	98,96	106,67	168,11	224,67

VOLVEDORES PARA TERRAJAS DE ROSCAR

Ref. VA

DIN 225



IMPORTANTE: A la hora de cursar sus pedidos de volvedores, indiquen el espesor del volvedor que corresponda, según detalle de espesores que indicamos en la tarifa de terrajas.

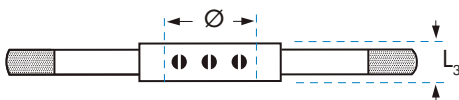

VA													
Ø x L3 mm	16x5	20x5	20x7	25x9	30x11	38x10	38x14	45x14	45x18	55x16	55x22	65x18	65x25
€	8,08	8,95	8,95	10,22	12,37	16,18	16,16	19,86	20,01	25,67	26,89	36,79	36,79
Ø x L3 mm	75x20	75x30	90x22	90x36	105x22	105x36	120x22	120x36	130x25	130x36	140x25	140x36	
€	63,74	66,72	80,74	86,99	95,56	95,56	248,52	248,52	258,37	258,37	271,70	271,70	

Ref. VA

PULGADAS



VA									
Ø mm	20,60	25,40	38,10	44,40	50,80	63,50	76,20	88,90	
PULGADAS	13/16"	1"	1.1/2"	1.3/4"	2"	2.1/2	3	3.1/2	
€	8,77	10,40	15,56	20,60	23,09	36,43	67,37	85,34	

NOTA: Los volvedores para terrajas en Ø exteriores en pulgadas, están en desuso.

GIRAMACHOS EN T CON CRIQUE

Ref. TC

TIPO
T

SERIE CORTA



	CAPACIDAD mm mín.-máx.	Para mangos de machos		L ₁ mm	PESO g	CALIDAD	TC
		DIN	ISO				€
TC3B	2,6 - 5,5	M3 - 8	M3 - 6	85	180	1º Calidad	22,30
TC4B	4,6 - 8,0	M5 - 12	M6 - 12	110	300	1º Calidad	30,12
TC1B	2,6 - 5,5	M3 - 8	M3 - 6	85	180	2º Calidad	16,88
TC2B	4,6 - 8,0	M5 - 12	M6 - 12	110	300	2º Calidad	22,64

Ref. TL

TIPO
T

SERIE LARGA



	CAPACIDAD mm mín.-máx.	Para mangos de machos		L ₁ mm	PESO g	CALIDAD	TL
		DIN	ISO				€
TL3	2,6 - 5,5	M3 - 8	M3 - 6	250	250	1º Calidad	35,17
TL4	4,6 - 8,0	M5 - 12	M6 - 12	300	440	1º Calidad	41,87
TL1	2,6 - 5,5	M3 - 10	M3 - 6	250	250	2º Calidad	27,77
TL2	4,6 - 8,0	M5 - 12	M6 - 12	300	440	2º Calidad	33,09

EXPOSITOR DE METACRILATO

Dimensiones: 500 x 320 x 110 mm

				GV-01		
					€	
GV-01	Nº $\frac{1\ 1/2}{5}$	Nº $\frac{2}{5}$	$\frac{20 \times 5}{5}$ $\frac{20 \times 7}{5}$ $\frac{25 \times 9}{5}$ $\frac{30 \times 11}{5}$ $\frac{38 \times 14}{5}$	TC1 4	TC2 4	626,38

CONJUNTOS DE MACHOS Y COJINETES EN CAJA METÁLICA HSS

**M3
M12**

HSS



Ref. D624

CONTENIDO

					Nº Piezas	1ª Calidad €	2ª Calidad €
D624	M3 - M4 - M5 - M6 - M8 - M10 - M12	Nº 1.1/2	25 x 9	-	30	243,37	220,77

CONJUNTOS DE COJINETES EN CAJA METÁLICA HSS



**M3
M12**

HSS



Ref. D671

CONTENIDO

				Nº Piezas	1ª Calidad €	2ª Calidad €	
D671	M3 - M4 - M5 - M6 - M8 - M10 - M12	20 x 5 30 x 11	20 x 7 38 x 14	25 x 9	12	207,75	175,96
D6711 (lza)	M3 - M4 - M5 - M6 - M8 - M10 - M12	20 x 5 30 x 11	20 x 7 38 x 14	25 x 9	12	415,48	351,90

CONJUNTOS DE MACHOS Y COJINETES EN CAJA METÁLICA HSS Y HSSCo
**M3
M12**

HSS

Ref. D621



Ref. D655

CONTENIDO

						Nº Piezas	1º Calidad €	2º Calidad €
D621	M3 - M4 - M5 - M6 M8 - M10 - M12	2.5 / 3.3 / 4.2 / 5.0 6.8 / 8.5 / 10.2 mm	Nº 1 Nº 2	20 x 5 20 x 7 25 x 9 30 x 11 38 x 14	TC1	43	422,30	309,53
D652	M3 - M4 - M5 - M6 M8 - M10 - M12	2.5 / 3.3 / 4.2 / 5.0 6.8 / 8.5 / 10.2 mm	Nº 1 Nº 2	20 x 5 20 x 7 25 x 9 30 x 11 38 x 14	-	42	408,78	293,94
D662	M3-M4-M5-M6-M7 M8-M9-M10-M11-M12	-	Nº 1 Nº 2	20 x 5 20 x 7 25 x 9 30 x 11 38 x 14	TC1	48	817,83	719,35
D651	M3 - M4 - M5 - M6 M8 - M10 - M12	-	Nº 1 Nº 2	20 x 5 20 x 7 25 x 9 30 x 11 38 x 14	-	35	322,64	296,82
D655* (HSSCo)	M3 - M4 - M5 - M6 M8 - M10 - M12	2.5 / 3.3 / 4.2 / 5.0 6.8 / 8.5 / 10.2 mm	Nº 1 Nº 2	20 x 5 20 x 7 25 x 9 30 x 11 38 x 14	TC1	43	673,68	592,58
D621I (Izq)	M3 - M4 - M5 - M6 M8 - M10 - M12	2.5 / 3.3 / 4.2 / 5.0 6.8 / 8.5 / 10.2 mm	Nº 1 Nº 2	20 x 5 20 x 7 25 x 9 30 x 11 38 x 14	TC1	43	659,54	575,18

*

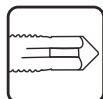
**HSSCo
5%**

CONJUNTOS DE MACHOS Y COJINETES EN CAJA METÁLICA HSS Y HSSCo CON GUÍAS PARA COJINETES

**M3
M12**



HSS

Machos y Terrajas

Verde



Ref. D656



Ref. D657

CONTENIDO

							Nº Piezas	1ª Calidad €	2ª Calidad €
D656	M3 - M4 - M5 - M6 M8 - M10 - M12		2.5 / 3.3 / 4.2 / 5.0 6.8 / 8.5 / 10.2 mm	Nº 1 Nº 2	20 x 5 20 x 7 25 x 9 30 x 11 38 x 14	TC1	43	471,91	417,75
D657* (HSSCo)	M3 - M4 - M5 - M6 M8 - M10 - M12		2.5 / 3.3 / 4.2 / 5.0 6.8 / 8.5 / 10.2 mm	Nº 1 Nº 2	20 x 5 20 x 7 25 x 9 30 x 11 38 x 14	TC1	43	702,52	620,06

* **HSSCo 5%**

CONJUNTOS DE MACHOS Y COJINETES EN CAJA METÁLICA HSS Y HSSCo
**M3
M20**
**M5
M20**
HSS

Machos y Terrajas

Verde





Ref. D622



Ref. D623

CONTENIDO

					Nº Piezas	1ª Calidad €	2ª Calidad €
D622	M3 - M4 - M5 - M6 - M8 - M10 - M12 M14 - M16 - M18 - M20	Nº 1 Nº 3	20 x 5 20 x 7 25 x 9 30 x 11 38 x 14 45 x 18	TC1 TC2	54	790,71	608,44
D658	M3 - M4 - M5 - M6 - M8 - M10 - M12 M14 - M16 - M18 - M20	Nº 1 Nº 3	20 x 5 20 x 7 25 x 9 30 x 11 38 x 14 45 x 18	-	52	728,43	628,18
D6221 (Izq)	M3 - M4 - M5 - M6 - M8 - M10 - M12 M14 - M16 - M18 - M20	Nº 1 Nº 3	20 x 5 20 x 7 25 x 9 30 x 11 38 x 14 45 x 18	TC1 TC2	54	1.243,83	1.179,29
D659* (HSSCo)	M3 - M4 - M5 - M6 - M8 - M10 - M12 M14 - M16 - M18 - M20	Nº 1 Nº 3	20 x 5 20 x 7 25 x 9 30 x 11 38 x 14 45 x 18	-	52	1.500,34	1.319,69
D623	M5 - M6 - M8 - M10 - M12 M14 - M16 - M18 - M20	Nº 1 Nº 3	20 x 7 25 x 9 30 x 11 38 x 14 45 x 18	TC1 TC2	45	757,27	592,87
D663	M5 - M6 - M7 - M8 - M9 - M10 - M12 M14 - M16 - M18 - M20	Nº 1 Nº 3	20 x 7 25 x 9 30 x 11 38 x 14 45 x 18	-	51	1.009,61	908,12

*

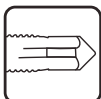
**HSSCo
5%**

CONJUNTOS DE MACHOS Y COJINETES EN CAJA METÁLICA Y DE MADERA HSS

**M1
M10**

**M5
M12**

**M3
M24**

**M5
M30**

HSS







Ref. D628

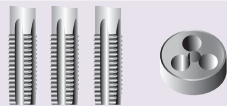

Ref. D626

CONTENIDO

					Nº Piezas	1ª Calidad €	2ª Calidad €
D626	M1 - M1.2 - M1.4 - M1.7 - M2.0 - M2.3 M2.6 - M3 - M3.5 - M4 - M5 - M6 - M8 - M10	Nº 0 Nº 1	16 x 5 20 x 5 20 x 7 25 x 9 30 x 11	TC1	64		944,67
D627	M5 - M6 - M7 - M8 - M9 - M10 - M11 - M12	Nº 1 Nº 2	20 x 7 25 x 9 30 x 11 38 x 14	TC1	39		705,71
D625	M3 - M4 - M5 - M6 - M8 - M10 - M12 - M14 M16 - M18 - M20 - M22 - M24	Nº 1 Nº 4	20 x 5 20 x 7 25 x 9 30 x 11 38 x 14 45 x 18 55 x 22	-	61	1.666,82	1.229,84
D628	M5 - M6 - M8 - M10 - M12 - M14 - M16 M18 - M20 - M22 - M24 - M27 - M30	Nº 1 Nº 3 Nº 5	20 x 7 25 x 9 30 x 11 38 x 14 45 x 18 55 x 22 65 x 25	-	62		2.251,08

CONJUNTOS DE MACHOS Y COJINETES EN CAJA METÁLICA HSS
MF
HSS

Machos y Terrajas

Verde







Ref. D634

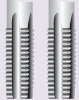

Ref. D636

CONTENIDO

						Nº Piezas	1ª Calidad €	2ª Calidad €
D634	MF 3 x 0.35 - 4 x 0.5 - 5 x 0.5 MF 6 x 0.75 - 8 x 0.75 - 8 x 1.0 MF 10 x 1.0 - 12 x 1.5		Nº 1 Nº 2	20 x 5 25 x 9 30 x 11 38 x 10	TC1	31		647,47
D635	MF 6 x 0.75 - 8 x 0.75 - 8 x 1.0 - 10 x 1.0 MF 12 x 1.0 - 12 x 1.5 - 14 x 1.25 - 14 x 1.5 MF 16 x 1.5 - 18 x 1.5 - 20 x 1.5		Nº 1 Nº 3	20 x 7 25 x 9 30 x 11 38 x 10 45 x 14	-	40	1.056,15	1.004,33
D636	MF 6 x 0.75 - 8 x 0.75 - 8 x 1.0 - 10 x 1.0 MF 12 x 1.0 - 12 x 1.5 - 14 x 1.25 - 14 x 1.5 MF 16 x 1.5 - 18 x 1.5 - 20 x 1.5 - 22 x 1.5 MF 24 x 1.5		Nº 1 Nº 4	20 x 7 25 x 9 30 x 11 38 x 10 45 x 14 55 x 16	-	47	1.448,85	1.339,56

CONJUNTOS DE MACHOS Y COJINETES EN CAJA METÁLICA HSS





**BSP
(GAS)**

HSS

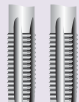

Ref. D638

CONTENIDO

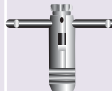
						Nº Piezas	1ª Calidad €	2ª Calidad €
D637	G 1/8 - 1/4 - 3/8 - 1/2 - 3/4 - 1"		Nº 1 Nº 3 Nº 5	30 x 11 38 x 10 45 x 14 55 x 16 65 x 18	-	26	1.172,66	947,26
D638	G 1/8 - 1/4 - 3/8 - 1/2 - 5/8 - 3/4 - 7/8 - 1"		Nº 1 Nº 3 Nº 5	30 x 11 38 x 10 45 x 14 55 x 16 65 x 18	-	32	1.591,42	1.389,19
D639	G 1/4 - 3/8 - 1/2 - 3/4 - 1" - 1".1/4 - 1".1/2		Nº 2 Nº 4 Nº 7	38 x 10 45 x 14 55 x 16 65 x 18 75 x 20 90 x 22	-	30	2.935,90	2.476,55



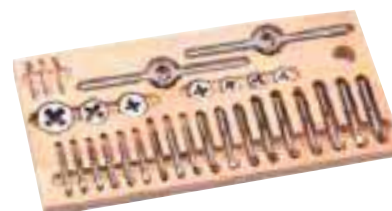

BSW

HSS

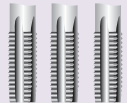

Ref. D640



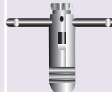

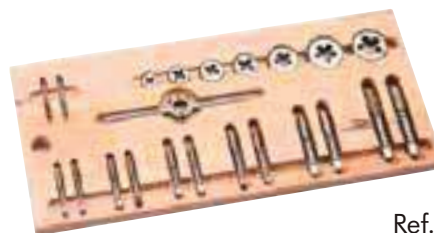
CONTENIDO

						Nº Piezas	1ª Calidad €	2ª Calidad €
D640	BSW 1/8 - 3/16 - 1/4 - 5/16 - 3/8 - 7/16 - 1/2		Nº 1 Nº 2	20 x 5 20 x 7 25 x 9 30 x 11 38 x 14	TC1	36	654,18	559,22
D641	BSW 1/4 - 5/16 - 3/8 - 7/16 - 1/2		Nº 1 Nº 2	20 x 7 25 x 9 30 x 11 38 x 14	TC1	27	539,29	454,23
D642	BSW 1/4 - 5/16 - 3/8 - 7/16 - 1/2 - 5/8 - 3/4		Nº 1 Nº 3	20 x 7 25 x 9 30 x 11 38 x 14 45 x 18	-	35	965,13	880,64
D643	BSW 1/4 - 5/16 - 3/8 - 7/16 1/2 - 5/8 - 3/4 - 7/8 - 1"		Nº 1 Nº 4	20 x 7 25 x 9 30 x 11 38 x 14 45 x 18 55 x 22	-	44	1.364,91	1.198,34
D646	BSW 1/4 - 5/16 - 3/8 - 7/16 1/2 - 5/8 - 3/4 - 7/8 - 1" - 1".1/8 1".1/4 - 1".3/8 - 1".1/2		Nº 1 Nº 3 Nº 5	20 x 7 25 x 9 30 x 11 38 x 14 45 x 18 55 x 22 65 x 25	-	62		3.641,48

CONJUNTOS DE MACHOS Y COJINETES EN CAJA METÁLICA HSS
BSF
HSS

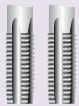
Ref. D648

CONTENIDO

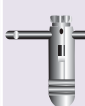
						Nº Piezas	1ª Calidad €	2ª Calidad €
D664	BSF 1/4 - 5/16 - 3/8 - 7/16 - 1/2		Nº 1 Nº 2	20 x 7 25 x 9 30 x 11 38 x 10	TC1	22	603,08	530,46
D648	BSF 1/4 - 5/16 - 3/8 - 7/16 - 1/2 - 5/8 - 3/4		Nº 1 Nº 3	20 x 7 25 x 9 30 x 11 38 x 10 45 x 14	-	28	936,22	880,64
D665	BSF 1/4 - 5/16 - 3/8 - 7/16 1/2 - 5/8 - 3/4 - 7/8 - 1"		Nº 1 Nº 4	20 x 7 25 x 9 30 x 11 38 x 10 45 x 14 55 x 16	-	35	1.588,60	1.397,32

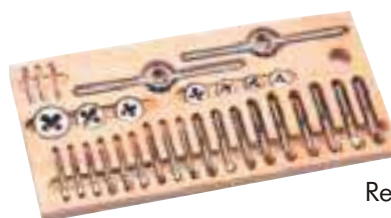
**BSW
BSF**
HSS

Ref. D666

CONTENIDO

						Nº Piezas	1ª Calidad €	2ª Calidad €
D666	BSW 1/4 - 5/16 - 3/8 - 7/16 - 1/2 - 5/8 - 3/4 BSF 1/4 - 5/16 - 3/8 - 7/16 - 1/2 - 5/8 - 3/4		Nº 1 Nº 3	20 x 7 25 x 9 30 x 11 38 x 14 x 45 x 18	-	63	1.794,53	1.578,45

CONJUNTOS DE MACHOS Y COJINETES EN CAJA METÁLICA HSS



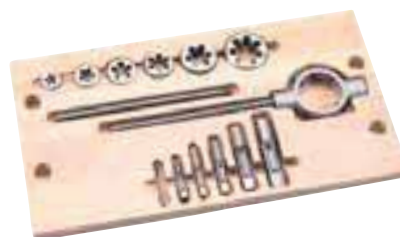

NPT

HSS



Ref. D660

CONTENIDO

						Nº Piezas	1ª Calidad €	2ª Calidad €
D660	NPT 1/8 - 1/4 - 3/8 - 1/2 - 3/4 - 1"		Nº1 Nº3 Nº5	30 x 11 38 x 14 45 x 18 55 x 22 65 x 25	-	20	1.696,30	1.609,02
D661	NPT 1/8 - 1/4 - 3/8 - 1/2 - 5/8 - 3/4 1" - 1".1/4 - 1".1/2 - 2"		Nº 2 Nº 4 Nº 7	30 x 11 38 x 14 45 x 18 55 x 22 65 x 25 75 x 30 90 x 36 105 X 36	-	31	5.077,85	4.770,62



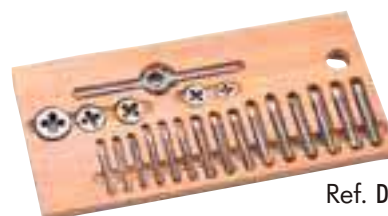

UNC

HSS

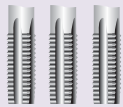

Ref. D650

CONTENIDO

						Nº Piezas	1ª Calidad €	2ª Calidad €
D650	UNC 1/4 - 5/16 - 3/8 - 7/16 - 1/2		Nº 1 Nº 2	20 x 7 25 x 9 30 x 11 38 x 14	TC1	27	657,33	589,98
D667	UNC 1/4 - 5/16 - 3/8 - 7/16 - 1/2 - 5/8 - 3/4		Nº 1 Nº 2	20 x 7 25 x 9 30 x 11 38 x 14 45 x 18	-	35	1.059,07	931,54
D654	UNC 1/4 - 5/16 - 3/8 - 7/16 1/2 - 5/8 - 3/4 - 7/8 - 1"		Nº 1 Nº 4	20 x 7 25 x 9 30 x 11 38 x 14 45 x 18 55 x 22	-	44	1.708,90	1.599,32
D668	UNC 1/4 - 5/16 - 3/8 - 7/16 - 1/2 - 5/8 - 3/4 7/8 - 1" - 1.1/8 - 1".1/4 - 1".3/8 - 1".1/2"		Nº 1 Nº 3 Nº 6	20 x 7 25 x 9 30 x 11 38 x 14 45 x 18 55 x 22 65 x 25	-	62	4.000,91	3.519,17

CONJUNTOS DE MACHOS Y COJINETES EN CAJA METÁLICA HSS



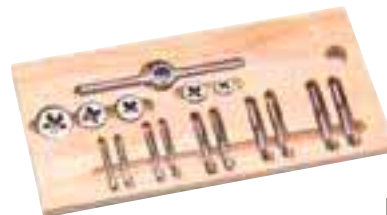

UNF

HSS

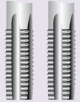

Ref. D644

CONTENIDO

						Nº Piezas	1ª Calidad €	2ª Calidad €
D644	UNF 1/4 - 5/16 - 3/8 - 7/16 - 1/2		Nº 1 Nº 2	20 x 7 25 x 9 30 x 11 38 x 10	TC1	22	515,08	446,53
D669	UNF 1/4-5/16 -3/8 -7/16 -1/2 -5/8 -3/4		Nº 1 Nº 3	20 x 7 25 x 9 30 x 11 38 x 10 45 x 14	-	28	970,81	853,91
D645	UNF 1/4 - 5/16 - 3/8 - 7/16 - 1/2 - 5/8 3/4 - 7/8 - 1"		Nº 1 Nº 4	20 x 7 25 x 9 30 x 11 38 x 10 45 x 14 55 x 16	-	34	1.190,40	1.079,34



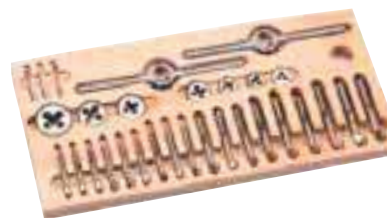

UNC
UNF

HSS

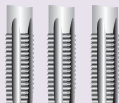

Ref. D670

CONTENIDO

						Nº Piezas	1ª Calidad €	2ª Calidad €
D670	UNC 1/4 - 5/16 - 3/8 - 7/16 - 1/2 - 5/8 - 3/4 UNF 1/4 - 5/16 - 3/8 - 7/16 - 1/2 - 5/8 - 3/4		Nº 1 Nº 3	20 x 7 25 x 9 30 x 11 38 x 14 x 45 x 18	-	35	1.794,53	1.578,45

JUEGOS DE MACHOS DE MANO HSS Y TiN EN ESTUCHES METÁLICOS



Ref. JMB0



Ref. JMB2



Ref. JMBT2

CONTENIDO

					HSS €		TiN €
JMB2	M3 - M4 - M5 - M6 M8 - M10 - M12	-	-	-	166,75	JMBT2	331,09
JMB0	M3 - M4 - M5 - M6 M8 - M10 - M12	2.5 / 3.3 / 4.2 / 5.0 6.8 / 8.5 / 10.2 mm	-	-	190,21	JMBT0	371,55
JMB1	M3 - M4 - M5 - M6 M8 - M10 - M12	2.5 / 3.3 / 4.2 / 5.0 6.8 / 8.5 / 10.2 mm	Nº 1.1/2	-	204,71	JMBT1	318,38
JMB5	M3 - M4 - M5 - M6 M8 - M10 - M12	2.5 / 3.3 / 4.2 / 5.0 6.8 / 8.5 / 10.2 mm	Nº 1.1/2	TC1	217,43	JMBT5	333,61
JMBI2 (Izq)	M3 - M4 - M5 - M6 M8 - M10 - M12	-	-	-	309,23	JMBIT2	575,16
JMBI0 (Izq)	M3 - M4 - M5 - M6 M8 - M10 - M12	2.5 / 3.3 / 4.2 / 5.0 6.8 / 8.5 / 10.2 mm	-	-	358,23	JMBIT0	623,84
JMBI1 (Izq)	M3 - M4 - M5 - M6 M8 - M10 - M12	2.5 / 3.3 / 4.2 / 5.0 6.8 / 8.5 / 10.2 mm	Nº 1.1/2	-	372,21	JMBIT1	636,77

MACHOS TERCEROS DE MANO HSS Y TiN EN ESTUCHES METÁLICOS



Ref. JMB3



Ref. JMB4

CONTENIDO

					HSS €		TiN €
JMB3	M3 - M4 - M5 - M6 M8 - M10 - M12	-	-	-	76,55	JMBT3	95,86
JMB4	M3 - M4 - M5 - M6 M8 - M10 - M12	2.5 / 3.3 / 4.2 / 5.0 6.8 / 8.5 / 10.2 mm	-	-	95,27	JMBT4	126,64
JMB7	M3 - M4 - M5 - M6 M8 - M10 - M12	2.5 / 3.3 / 4.2 / 5.0 6.8 / 8.5 / 10.2 mm	Nº 1.1/2	-	161,97	JMBT7	175,66
JMB6	M3 - M4 - M5 - M6 M8 - M10 - M12	2.5 / 3.3 / 4.2 / 5.0 6.8 / 8.5 / 10.2 mm	Nº 1.1/2	TC1	120,36	JMBT6	187,22
JMBI3 (Izq)	M3 - M4 - M5 - M6 M8 - M10 - M12	-	-	-	103,06	JMBIT3	191,71
JMBI4 (Izq)	M3 - M4 - M5 - M6 M8 - M10 - M12	2.5 / 3.3 / 4.2 / 5.0 6.8 / 8.5 / 10.2 mm	-	-	138,11	JMBIT4	254,12

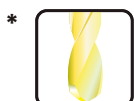

MACHOS DE MANO HSSCo EN ESTUCHES METÁLICOS

Ref. JMBX0

CONTENIDO

INOX					HSSCo 5% €
JMBX0	M3 - M4 - M5 - M6 M8 - M10 - M12	2.5 / 3.3 / 4.2 / 5.0 6.8 / 8.5 / 10.2 mm	-	-	262,85
JMBX1	M3 - M4 - M5 - M6 M8 - M10 - M12	2.5 / 3.3 / 4.2 / 5.0 6.8 / 8.5 / 10.2 mm	Nº 1.1/2	-	276,63
JMBX2	M3 - M4 - M5 - M6 M8 - M10 - M12	-	-	-	248,55

CONTENIDO

1200 N/mm ²					HSSCo 5% €
JMBMD0	M3 - M4 - M5 - M6 M8 - M10 - M12	2.5 / 3.3 / 4.2 / 5.0 6.8 / 8.5 / 10.2 mm	-	-	274,50
JMBMD1	M3 - M4 - M5 - M6 M8 - M10 - M12	2.5 / 3.3 / 4.2 / 5.0 6.8 / 8.5 / 10.2 mm	Nº 1.1/2	-	288,78
JMBMD2	M3 - M4 - M5 - M6 M8 - M10 - M12	-	-	-	261,66

ESTUCHES DE COJINETES EN CAJAS METÁLICAS HSS

Ref. C5B3

CONTENIDO

		HSS €
C5B3	M3 - M4 - M5 - M6 - M8 - M10 - M12	197,32
C5B3I (Izq)	M3 - M4 - M5 - M6 - M8 - M10 - M12	390,82

EXTRACTOR DE MACHOS ROTOS PARA MACHOS DE CANALES RECTOS - NO HELICOIDALES



EXTRACTORES SUELTOS

Ø MACHO A EXTRAER		MACHOS DE MANO	MACHOS DE MÁQUINA	€/ Ud.
BSW UNC	M			EXTRACTOR COMPLETO
--	M3		10.043	37,63
1/8	M3,2		10.053	37,63
--	M3,5		10.063	37,63
5/32	M4		10.083	37,63
3/16	M5		10.103	37,63
--	M5,5	10.124	10.123	37,63
1/4	M6		10.253	38,73
5/16	M8	10.314	10.313	40,59
--	M9	10.374	10.373	40,20
3/8	M10	10.404	10.373	40,20
7/16	M11	10.434	10.433	42,44
1/2	M12	10.504	10.503	45,38
9/16	M14	10.564	10.563	62,72
5/8	M16	10.624	10.623	68,26
--	M18	10.684	10.753	84,58
3/4	M20	10.754	10.753	84,58
7/8	M22	10.874	10.873	92,54
1"	M25	11.004	11.003	103,20

VARILLA REPUESTO

MACHOS DE MANO	MACHOS DE MÁQUINA	€/ Ud.
		VARILLA EXTRA
	12.043	2,00
	12.053	2,00
	12.063	2,00
	12.083	2,00
	12.103	2,99
	12.123	2,99
	12.253	3,64
12.314	12.313	4,11
12.374		4,11
12.404	12.373	4,24
12.434	12.433	4,31
12.504	12.503	5,42
12.564	12.563	6,05
12.624	12.623	7,73
12.684		7,73
12.754	12.753	8,18
12.874	12.873	10,61
13.004	13.003	17,65

3 SIMPLES PASOS PARA EXTRAER MACHOS DE ROSCAR ROTOS DE CANALES RECTOS

Sacar toda la viruta del macho roto. Introducir las varillas del extractor en los canales del macho roto con firmeza hasta el fondo.



Empujar el soporte hacia abajo, hasta tocar el macho roto. Deslice el casquillo hacia abajo, hasta tocar la zona de trabajo.



Aplicar al cuadradillo del extractor un gira-machos. Gire a izquierdas unas cuantas veces hasta soltarlo y entonces saque el macho roto.







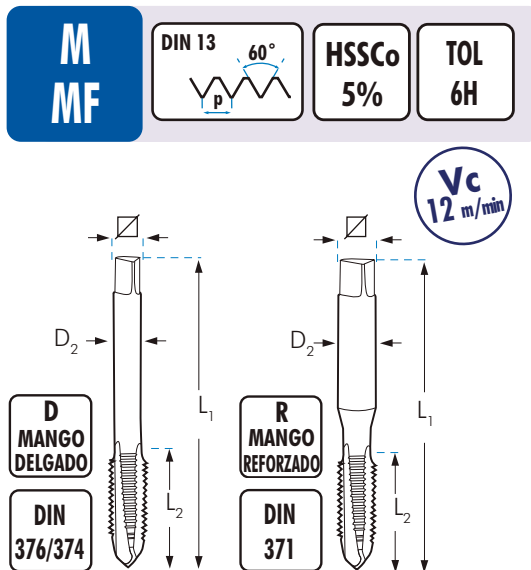

JUEGOS DE EXTRACTORES PARA MACHOS ROTOS (CANALES RECTOS)



	MEDIDAS INCLUIDAS PARA MACHOS DE MÁQUINA: 3 y 4 CANALES	
18.001.3	M5- M6- M8- M10- M11- M12 3/16 - 1/4 - 5/16 - 3/8 - 7/16 - 1/2	260,86
18.002.3	M6- M8 -M10- M11- M12- M16 1/4 - 5/16 - 3/8 - 7/16 - 1/2 - 5/8	293,49
18.015.3	M3- M3,2- M3,5- M4-M5- M5,50- M6- M8 M9- M10- M12- M16- M18- M22- M25	820,96

MACHOS PARA ROSCAR A MÁQUINA HSSCo

		L ₁ x L ₂ x D ₂ x \square mm	M1D	M2D	M3D	M4D	M1R	M2R	M3R	M4R
			FORMA C €	FORMA B €	 €	 €	FORMA C €	FORMA B €	 €	 €
M 1x0,25	0,75	R 40 x 6 x 2,5 x 2,1					33,78			
M 1,1x0,25	0,85	R 40 x 6 x 2,5 x 2,1					32,86			
M 1,2x0,25	0,95	R 40 x 6 x 2,5 x 2,1					30,59			
M 1,4x0,30	1,10	R 40 x 7 x 2,5 x 2,1					30,59			
M 1,6x0,35	1,25	R 40 x 8 x 2,5 x 2,1					30,04			
M 1,7x0,35	1,35	R 40 x 8 x 2,5 x 2,1					28,93			
M 1,8x0,35	1,45	R 40 x 8 x 2,5 x 2,1					28,22			
M 2x0,40	1,60	R 40 x 9 x 2,8 x 2,1					13,11	14,52	17,14	16,83
M 2,2x0,45	1,75	R 40 x 9 x 2,8 x 2,1					14,68			
M 2,3x0,40	1,90	R 40 x 9 x 2,8 x 2,1					13,52			
M 2,5x0,45	2,05	R 50 x 9 x 2,8 x 2,1					13,11	14,52	23,65	16,83
M 2,6x0,45	2,10	R 50 x 9 x 2,8 x 2,1					13,36	14,78		29,04
M 3x0,50	2,50	R 56 x 11 x 3,5 x 2,7 D 56 x 11 x 2,2 x 1,8	9,17	10,03	14,00	12,08	9,17*	9,40	13,61	12,38
M 3x0,60	2,40	R 56 x 11 x 3,5 x 2,7					16,00	17,78		23,05
M 3,5x0,60	2,90	R 56 x 12 x 4,0 x 3,0 D 56 x 12 x 2,5 x 2,1					12,62	13,38	16,96	16,22
M 3,5x0,75	2,75	R 56 x 12 x 4,0 x 3,0					16,97			
M 4x0,50	3,50	R 63 x 13 x 4,5 x 3,4 D 63 x 13 x 2,8 x 2,1	19,19	21,59		23,59	18,83	20,94		24,25
M 4x0,70	3,30	R 63 x 13 x 4,5 x 3,4 D 63 x 13 x 2,8 x 2,1	9,33	10,18	14,01	11,97	9,88*	9,93	13,37	12,39
M 4x0,75	3,25	R 63 x 13 x 4,5 x 3,4					14,05	15,58		
M 4x0,80	3,20	R 63 x 13 x 4,5 x 3,4					74,60			
M 4,5x0,50	4,00	R 70 x 14 x 6,0 x 4,9						24,37		
M 4,5x0,75	3,75	R 70 x 14 x 6,0 x 4,9					17,05	19,13		
M 5x0,50	4,50	R 70 x 14 x 6,0 x 4,9 D 70 x 11 x 3,5 x 2,7	19,76	22,19		23,86	19,39	21,52		25,87
M 5x0,75	4,50	R 74 x 14 x 6,0 x 4,9 D 70 x 16 x 3,5 x 2,7					17,39	20,40		25,70
M 5x0,80	4,20	R 70 x 16 x 6,0 x 4,9 D 70 x 16 x 3,5 x 2,7	9,33	10,18	13,43	11,43	9,43*	9,95	12,82	11,88
M 5x0,90	4,10	R 70 x 15 x 6,0 x 4,9 D 70 x 16 x 3,5 x 2,7					14,85	19,48		
M 5x1,00	4,00	R 72 x 17 x 6,0 x 4,9					39,77			
M 5,5x0,90	4,60	R 80 x 17 x 6,0 x 4,9					39,77			
M 6x0,50	5,50	R 80 x 17 x 6,0 x 4,9 D 80 x 13 x 4,5 x 3,4	23,40	29,32		37,51	24,92			
M 6x0,75	5,25	R 80 x 13 x 6,0 x 4,9 D 80 x 13 x 4,5 x 3,4	15,41	18,33		21,60	16,14	19,16		23,01
M 6x1,00	5,00	R 80 x 17 x 6,0 x 4,9 D 80 x 17 x 4,5 x 3,4	10,64	11,16	14,07	12,60	10,73*	10,91	14,07	13,03

* Disponibles también con rosca izquierda con 100% de recargo sobre los precios tarifados en rosca derecha



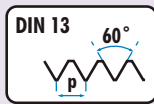

MACHOS PARA ROSCAR A MÁQUINA HSSCo

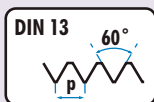
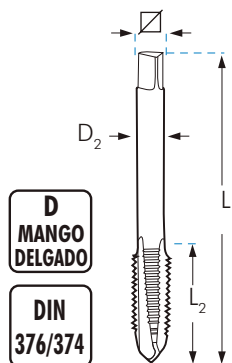

M	L1 x L2 x D2 x ∇ mm	R	M1D	M2D	M3D	M4D	M1R	M2R	M3R	M4R
			€	€	€	€	€	€	€	€
M 6x1,25	4,75	R 80 x 17 x 6,0 x 4,9					39,09			
M 7x0,75	6,25	D 80 x 13 x 5,5 x 4,3	20,57	22,61		28,57				
M 7x1,00	6,00	R 80 x 17 x 7,0 x 5,5 D 80 x 17 x 5,5 x 4,3	13,56	15,67	17,55	17,37	13,30*	15,52	17,55	17,37
M 8x0,50	7,50	D 80 x 13 x 6 x 4,9	26,45							
M 8x0,75	7,25	D 80 x 13 x 6 x 4,9	18,81	23,06		30,91				
M 8x1,00	7,00	D 90 x 20 x 6 x 4,9	15,67	17,99	21,92	20,11				
M 8x1,25	6,75	R 90 x 20 x 8 x 6,2 D 90 x 20 x 6 x 4,9	11,94	12,47	16,91	14,78	12,12*	12,24	16,59	14,81
M 8x1,50	6,50	D 90 x 20 x 6 x 4,9	78,84							
M 9x1,00	8,00	D 90 x 20 x 7 x 5,5	23,26	25,77		27,64				
M 9x1,25	7,80	R 90 x 20 x 9 x 7,0 D 90 x 20 x 7 x 5,5	19,37	20,74	24,65	24,55	19,54	20,55	25,31	25,49
M 10x0,50	9,50	D 90 x 20 x 7 x 5,5	78,11							
M 10x0,75	9,25	D 90 x 16 x 7 x 5,5	29,27	30,96		38,06				
M 10x1,00	9,00	D 90 x 16 x 7 x 5,5	17,35	19,99	25,88	24,24				
M 10x1,25	8,80	D 100 x 22 x 7 x 5,5	19,87	23,90	28,21	26,42				
M 10x1,50	8,50	R 100 x 22 x 10 x 8,0 D 100 x 22 x 7 x 5,5	13,62	15,37	19,92	17,54	13,74*	15,08	19,54	17,54
M 11x0,75	10,25	D 90 x 20 x 8 x 6,2								
M 11x1,00	10,00	D 90 x 20 x 8 x 6,2	29,96	32,67	82,59	75,87				
M 11x1,25	9,75	D 100 x 22 x 8 x 6,2	30,84	34,27	82,59	67,72				
M 11x1,50	9,50	D 100 x 22 x 8 x 6,2	24,54	26,97	60,22	55,29				
M 12x0,75	11,25	D 100 x 22 x 9 x 7,0	47,23							
M 12x1,00	11,00	D 100 x 22 x 9 x 7,0	23,60	26,26	31,93	30,47				
M 12x1,25	10,75	D 100 x 22 x 9 x 7,0	23,89	26,53	30,57	29,18				
M 12x1,50	10,50	D 100 x 22 x 9 x 7,0	21,35*	23,67	29,40	28,06				
M 12x1,75	10,20	D 100 x 24 x 9 x 7,0	16,40*	19,01	26,21	22,59				
M 13x0,75	12,25	D 100 x 22 x 11 x 9,0	82,43							
M 13x1,00	12,00	D 100 x 22 x 11 x 9,0	43,65	49,43						
M 13x1,25	11,75	D 100 x 22 x 11 x 9,0	43,65	49,43						
M 13x1,50	11,50	D 100 x 22 x 11 x 9,0	43,65	49,43						
M 13x1,75	11,25	D 100 x 22 x 11 x 9,0	42,53	49,43						
M 14x0,75	13,25	D 100 x 22 x 11 x 9,0	82,43							
M 14x1,00	13,00	D 100 x 22 x 11 x 9,0	37,28	41,01	49,23	48,81				
M 14x1,25	12,80	D 100 x 22 x 11 x 9,0	32,33	35,29	45,15	42,29				
M 14x1,50	12,50	D 100 x 22 x 11 x 9,0	25,43*	28,02	35,61	33,35				
M 14x2,00	12,00	D 110 x 26 x 11 x 9,0	25,26*	28,07	32,53	31,92				
M 15x1,00	14,00	D 100 x 22 x 12 x 9,0	48,31	53,00		66,23				
M 15x1,25	13,75	D 100 x 22 x 12 x 9,0	53,63	58,07						
M 15x1,50	13,50	D 100 x 22 x 12 x 9,0	42,86	47,17	122,55	101,30				
M 15x2,00	13,00	D 110 x 27 x 12 x 9,0	52,47	57,74						
M 16x1,00	15,00	D 100 x 22 x 12 x 9,0	45,53	50,07	68,92	66,92				
M 16x1,25	14,75	D 100 x 22 x 12 x 9,0	50,49	55,51	76,64	74,22				
M 16x1,50	14,50	D 100 x 22 x 12 x 9,0	30,07*	35,04	44,37	41,56				
M 16x2,00	14,00	D 110 x 27 x 12 x 9,0	29,73*	32,83	39,30	38,56				
M 17x1,00	16,00	D 100 x 22 x 12 x 9,0	93,89							
M 17x1,25	15,75	D 100 x 22 x 12 x 9,0	93,89							
M 17x1,50	15,50	D 100 x 22 x 12 x 9,0	93,89							
M 18x1,00	17,00	D 110 x 25 x 14 x 11,0	50,99	56,04		81,89				
M 18x1,25	16,75	D 110 x 25 x 14 x 11,0	65,50							
M 18x1,50	16,50	D 110 x 25 x 14 x 11,0	39,81*	43,81	54,52	51,19				
M 18x2,00	16,00	D 125 x 30 x 14 x 11,0	54,12	61,66	107,89	98,13				

* Disponibles también con rosca izquierda con 100% de recargo sobre los precios tarifados en rosca derecha

MACHOS PARA ROSCAR A MÁQUINA HSSCo
**M
MF**

**HSSCo
5%**
**TOL
6H**
**D
MANGO
DELGADO**
**DIN
376/374**
**Vc
12
m/min**

**D
MANGO
DELGADO**
**DIN
376/374**

			$L_1 \times L_2 \times D_2 \times \square$ mm	M1D	M2D	M3D	M4D
				FORMA C €	FORMA B €	 €	 €
M 18x2,50	15,50	D 125 x 30 x 14 x 11,0	42,77*	46,77	52,91	50,95	
M 19x1,00	18,00	D 110 x 22 x 14 x 11,0	123,36				
M 19x1,25	17,75	D 110 x 25 x 14 x 11,0	124,49				
M 19x1,50	17,50	D 110 x 25 x 14 x 11,0	121,08				
M 19x2,00	17,00	D 110 x 25 x 14 x 11,0					
M 20x1,00	19,00	D 125 x 25 x 16 x 12,0	67,32	74,75		87,46	
M 20x1,25	18,75	D 125 x 25 x 16 x 12,0	123,36				
M 20x1,50	18,50	D 125 x 25 x 16 x 12,0	45,09*	49,55	61,28	58,48	
M 20x2,00	18,00	D 140 x 32 x 16 x 12,0	59,09	64,97		78,02	
M 20x2,50	17,50	D 140 x 32 x 16 x 12,0	45,53*	50,49	56,47	55,42	
M 21x1,00	20,00	D 125 x 25 x 16 x 12,0	179,11				
M 21x1,25	19,75	D 125 x 25 x 16 x 12,0	179,11				
M 21x1,50	19,50	D 125 x 25 x 16 x 12,0	171,05				
M 22x1,00	21,00	D 125 x 25 x 18 x 14,5	75,46	83,00		112,70	
M 22x1,25	20,75	D 125 x 25 x 18 x 14,5	123,36				
M 22x1,50	20,50	D 125 x 25 x 18 x 14,5	54,27	59,70	67,22	61,03	
M 22x2,00	20,00	D 140 x 32 x 18 x 14,5	75,46	83,00		112,70	
M 22x2,50	19,50	D 140 x 32 x 18 x 14,5	55,10*	60,60	69,41	66,28	
M 23x1,00	22,00	D 125 x 25 x 18 x 14,5	174,13				
M 23x1,50	21,50	D 125 x 25 x 18 x 14,5	174,13				
M 24x1,00	23,00	D 140 x 25 x 18 x 14,5	82,23	103,38		119,08	
M 24x1,25	22,75	D 140 x 25 x 18 x 14,5	179,11				
M 24x1,50	22,50	D 140 x 28 x 18 x 14,5	66,75	73,38	89,85	84,15	
M 24x2,00	22,00	D 140 x 28 x 18 x 14,5	85,16*	92,78		107,76	
M 24x3,00	21,00	D 160 x 34 x 18 x 14,5	65,96*	72,19	83,65	80,56	
M 25x1,00	24,00	D 140 x 28 x 18 x 14,5	159,15				
M 25x1,25	23,75	D 140 x 28 x 18 x 14,5	251,48				
M 25x1,50	23,50	D 140 x 28 x 18 x 14,5	103,85	113,91			
M 25x2,00	23,00	D 140 x 28 x 18 x 14,5	231,69	254,87			
M 26x1,00	25,00	D 140 x 28 x 18 x 14,5	123,56				
M 26x1,50	24,50	D 140 x 28 x 18 x 14,5	90,01	94,35	168,32	150,83	
M 26x2,00	24,00	D 140 x 28 x 18 x 14,5	231,69	254,87		105,75	
M 27x1,00	26,00	D 140 x 28 x 20 x 16,0	114,88	145,56			
M 27x1,50	25,50	D 140 x 28 x 20 x 16,0	98,28	107,90	244,62	224,77	
M 27x2,00	25,00	D 140 x 28 x 20 x 16,0	119,29*	128,63			

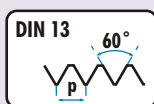
* Disponibles también con rosca izquierda con 100% de recargo sobre los precios tarifados en rosca derecha



MACHOS PARA ROSCAR A MÁQUINA HSSCo

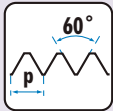
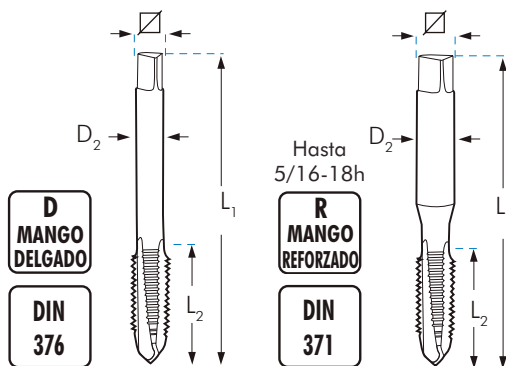

			L ₁ x L ₂ x D ₂ x	M1D	M2D	M3D	M4D
				FORMA C	FORMA B		
				€	€	€	€
M 27x3,00	24,00	D	160 x 36 x 20 x 16	82,34*	90,29	102,93	99,12
M 28x1,00	27,00	D	140 x 28 x 20 x 16	231,69			
M 28x1,50	26,50	D	140 x 28 x 20 x 16	98,28	107,90	127,39	117,20
M 28x2,00	26,00	D	140 x 28 x 20 x 16	119,70	135,19	150,13	150,44
M 30x1,00	29,00	D	150 x 28 x 22 x 18	125,71	150,64		175,63
M 30x1,50	28,50	D	150 x 28 x 22 x 18	102,44	112,72	138,15	129,37
M 30x2,00	28,00	D	150 x 28 x 22 x 18	126,80*	139,47		189,38
M 30x3,00	27,00	D	150 x 28 x 22 x 18				
M 30x3,50	26,50	D	180 x 40 x 22 x 18	105,51*	116,01	131,92	127,03
M 32x1,00	31,00	D	150 x 28 x 22 x 18	303,16	321,90		
M 32x1,50	30,50	D	150 x 28 x 22 x 18	129,62	142,31	170,20	
M 32x2,00	30,00	D	150 x 28 x 22 x 18	159,01	243,48		
M 33x1,00	32,00	D	160 x 30 x 25 x 20	284,52			
M 33x1,50	31,50	D	160 x 30 x 25 x 20	143,31	154,89		183,34
M 33x2,00	31,00	D	160 x 30 x 25 x 20	239,35	263,21		303,62
M 33x3,50	29,50	D	180 x 40 x 25 x 20	126,80*	145,90		167,71
M 34x1,50	32,50	D	170 x 30 x 28 x 22	165,41	178,56		
M 34x2,00	32,00	D	160 x 30 x 28 x 22	354,49			
M 35x1,50	33,50	D	170 x 30 x 28 x 22	171,53	188,67		209,83
M 35x2,00	33,00	D	170 x 30 x 28 x 22	321,00	353,38		
M 36x1,50	34,50	D	170 x 30 x 28 x 22	162,32	185,16		227,94
M 36x2,00	34,00	D	170 x 30 x 28 x 22	219,24	241,16		
M 36x3,00	33,00	D	200 x 50 x 28 x 22	251,53	276,65		329,91
M 36x4,00	32,00	D	200 x 50 x 28 x 22	164,82*	178,29	214,62	205,35
M 38x1,50	36,50	D	170 x 30 x 28 x 22	173,04	194,97		
M 38x2,00	36,00	D	170 x 32 x 28 x 22	367,80	404,60		
M 39x1,50	37,50	D	170 x 32 x 32 x 24	271,91			
M 39x2,00	37,00	D	170 x 32 x 32 x 24	271,91			
M 39x3,00	36,00	D	200 x 47 x 32 x 24	355,10			
M 39x4,00	35,00	D	200 x 50 x 32 x 24	206,92	227,62		
M 40x1,50	38,50	D	170 x 30 x 32 x 24	226,26	249,04		
M 40x2,00	38,00	D	170 x 30 x 32 x 24	272,63			
M 40x3,00	37,00	D	200 x 47 x 32 x 24	267,30	318,91		
M 42x1,50	40,50	D	170 x 30 x 32 x 24	238,22	255,33		
M 42x2,00	40,00	D	170 x 30 x 32 x 24	311,89			
M 42x3,00	39,00	D	200 x 45 x 32 x 24	311,89	387,85		
M 42x4,50	37,50	D	200 x 56 x 32 x 24	266,08	292,61		
M 45x1,50	43,50	D	180 x 32 x 36 x 29	284,52	312,94		
M 45x2,00	43,00	D	180 x 32 x 36 x 29	361,13			
M 45x3,00	42,00	D	200 x 47 x 36 x 29	361,13			
M 45x4,50	40,50	D	220 x 58 x 36 x 29	290,65	319,70		
M 48x1,50	46,50	D	190 x 32 x 36 x 29	290,65			
M 48x2,00	46,00	D	190 x 32 x 36 x 29	444,69			
M 48x3,00	45,00	D	220 x 52 x 36 x 29	437,63			
M 48x5,00	43,00	D	250 x 65 x 36 x 29	357,42	393,13		
M 50x1,50	48,50	D	190 x 32 x 36 x 29	339,91			
M 52x1,50	50,50	D	190 x 32 x 40 x 32	344,13			
M 52x2,00	50,00	D	190 x 32 x 40 x 32	544,59			
M 52x3,00	49,00	D	225 x 50 x 40 x 32	559,69			
M 52x5,00	47,00	D	250 x 65 x 40 x 32	366,04	444,44		

* Disponibles también con rosca izquierda con 100% de recargo sobre los precios tarifados en rosca derecha

MACHOS PARA ROSCAR A MÁQUINA HSSCo
UNC

HSSCo
5%
TOL
2B
Vc
12 m/min

 	D ₁ mm		L ₁ x L ₂ x D ₂ x \square mm	M1R	M2R	M3R	M4R
				FORMA C	FORMA B	15°	35°
				€	€	€	€
UNC n° 1-64h	1,85	1,50	R 40 x 8 x 2,5 x 2,1				
UNC n° 2-56h	2,18	1,80	R 45 x 9 x 2,8 x 2,1				
UNC n° 3-48h	2,51	2,10	R 50 x 9 x 2,8 x 2,1				
UNC n° 4-40h	2,84	2,25	R 56 x 11 x 3,5 x 2,7	20,55	24,66		28,14
UNC n° 5-40h	3,17	2,60	R 56 x 11 x 3,5 x 2,7	20,55	24,66		28,14
UNC n° 6-32h	3,50	2,75	R 56 x 12 x 4,0 x 3,0	19,56	23,50		26,79
UNC n° 8-32h	4,17	3,50	R 63 x 13 x 4,5 x 3,4	19,56	23,50		26,79
UNC n° 10-24h	4,83	3,90	R 70 x 15 x 6,0 x 4,9	20,55	24,66		28,14
UNC n° 12-24h	5,49	4,50	R 80 x 16 x 6,0 x 4,9	21,56	24,66		27,02
UNC 1/4-20h	6,35	5,10	R 80 x 17 x 7,0 x 5,5	19,21	20,95		24,17
UNC 5/16-18h	7,94	6,60	R 90 x 20 x 8,0 x 6,2	21,74	23,97		27,29

MANGO DELGADO				M1D	M2D	M3D	M4D
UNC 3/8-16h	9,52	8,00	D 100 x 22 x 7,0 x 5,5	24,79	27,19		30,55
UNC 7/16-14h	11,11	9,40	D 100 x 22 x 8,0 x 6,2	34,11	34,23		42,81
UNC 1/2-13h	12,70	10,75	D 110 x 24 x 9,0 x 7,0	37,02	41,02		46,82
UNC 9/16-12h	14,28	12,20	D 110 x 26 x 11,0 x 9,0	50,89	55,88		63,57
UNC 5/8-11h	15,87	13,50	D 110 x 27 x 12,0 x 9,0	49,44	54,42		61,82
UNC 3/4-10h	19,05	16,50	D 125 x 30 x 14,0 x 11,0	65,46	71,96		81,88
UNC 7/8-9h	22,22	19,50	D 140 x 32 x 18,0 x 14,5	86,14	94,63		128,12
UNC 1"-8h	25,40	22,25	D 160 x 36 x 18,0 x 14,5	113,81	124,33		160,72
UNC 1.1/8-7h	28,57	25,00	D 180 x 40 x 22,0 x 18,0	148,66			187,82
UNC 1.1/4-7h	31,75	28,00	D 180 x 40 x 22,0 x 18,0	182,24			240,27
UNC 1.3/8-6h	34,92	30,75	D 200 x 50 x 28,0 x 22,0	271,83			
UNC 1.1/2-6h	38,10	34,00	D 200 x 50 x 32,0 x 24,0	308,70			
UNC 1.3/4-5h	44,45	39,00	D 220 x 58 x 36,0 x 29,0				
UNC 2"-4,5h	50,80	45,00	D 250 x 65 x 40,0 x 32,0				

MACHOS PARA ROSCAR A MÁQUINA HSSCo

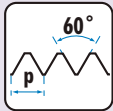
UNF



HSSCo
5%

TOL
2B

Vc
12 m/min

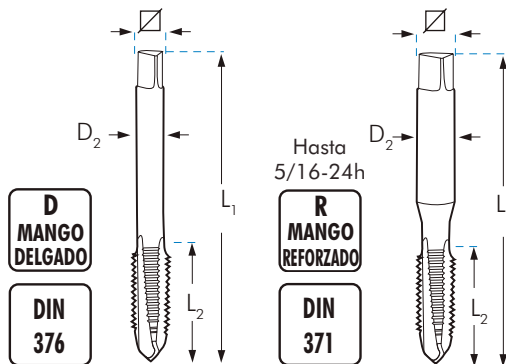

UNF nº	D1 mm	D2 mm	L1 x L2 x D2 x \square mm	M1R	M2R	M3R	M4R
				FORMA C	FORMA B	15°	35°
				€	€	€	€
UNF nº 1-72h	1,85	1,50	R 40 x 8 x 2,5 x 2,1				
UNF nº 2-64h	2,18	1,85	R 45 x 9 x 2,8 x 2,1				
UNF nº 3-56h	2,51	2,15	R 50 x 9 x 2,8 x 2,1				
UNF nº 4-48h	2,84	2,35	R 56 x 11 x 3,5 x 2,7	22,12	24,09		30,23
UNF nº 5-44h	3,17	2,70	R 56 x 11 x 3,5 x 2,7	22,12	24,09		30,23
UNF nº 6-40h	3,50	2,95	R 56 x 12 x 4,0 x 3,0	21,16	25,34		30,00
UNF nº 8-36h	4,17	3,50	R 63 x 13 x 4,5 x 3,4	21,16	25,34		30,00
UNF nº 10-32h	4,83	4,10	R 70 x 15 x 6,0 x 4,9	21,16	25,34		30,00
UNF nº 12-28h	5,49	4,60	R 80 x 16 x 6,0 x 4,9	22,12	26,51		30,23
UNF 1/4-28h	6,35	5,50	R 80 x 17 x 7,0 x 5,5	17,87	19,14		22,33
UNF 5/16-24h	7,94	6,90	R 90 x 20 x 8,0 x 6,2	19,61	22,03		25,75

MANGO DELGADO				M1D	M2D	M3D	M4D
UNF 3/8-24h	9,52	8,50	D 90 x 16 x 7,0 x 5,5	21,47	24,83		30,23
UNF 7/16-20h	11,11	9,90	D 100 x 22 x 8,0 x 6,2	26,99	32,84		38,74
UNF 1/2-20h	12,70	11,50	D 100 x 22 x 9,0 x 7,0	28,74	34,93		41,22
UNF 9/16-18h	14,29	12,90	D 100 x 22 x 11,0 x 9,0	35,31	42,93		51,04
UNF 5/8-18h	15,87	14,50	D 100 x 22 x 12,0 x 9,0	39,75	48,28		57,03
UNF 3/4-16h	19,05	17,50	D 110 x 25 x 14,0 x 11,0	50,86	61,84		72,95
UNF 7/8-14h	22,22	20,40	D 125 x 25 x 18,0 x 14,5	63,96	78,51		111,58
UNF 1"-12h	25,40	23,25	D 140 x 28 x 18,0 x 14,5	94,47	102,86		137,36
UNS 1"-14h	25,40	23,60	D 140 x 28 x 18,0 x 14,5	89,94	105,82		137,36
UNF 1.1/8-12h	28,57	26,50	D 150 x 28 x 22,0 x 18,0	143,94			
UNF 1.1/4-12h	31,75	29,50	D 150 x 28 x 22,0 x 18,0	181,90			
UNF 1.3/8-12h	34,92	33,00	D 170 x 30 x 28,0 x 22,0				
UNF 1.1/2-12h	38,10	36,00	D 170 x 30 x 32,0 x 24,0	305,29			
UNF 2"-12h	50,80	36,00	D 200 x 70 x 35,5 x 28,0				

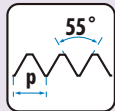
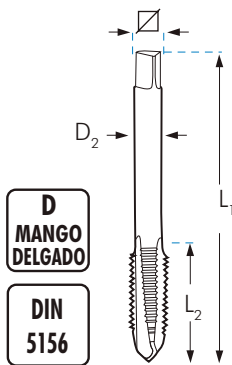
MACHOS PARA ROSCAR A MÁQUINA HSSCo
BSP
(GAS)

HSSCo
5%
TOL
ISO 228
INOX
Vc
12 m/min
Vc
6 m/min

		D1 mm		L1 x L2 x D2 x ∇ mm	M1D	M2D	M3D	M4D	M2DX	M4DX
					FORMA C	FORMA B	15°	35°	FORMA B	35°
					€	€	€	€	€	€
G 1/8-28h.	9,728	8,80	D 90 x 16 x 7 x 5,5	26,25*	29,99	32,13	31,83	49,00	51,00	
G 1/4-19h.	13,157	11,80	D 100 x 22 x 11 x 9,0	36,41*	40,08	46,14	45,71	66,02	74,30	
G 3/8-19h.	16,662	15,25	D 100 x 22 x 12 x 9,0	43,59*	47,96	55,11	54,59	78,32	87,33	
G 1/2-14h.	20,955	19,00	D 125 x 25 x 16 x 12,0	55,09	60,62	69,51	68,85	97,94	110,22	
G 5/8-14h.	22,911	21,00	D 125 x 25 x 18 x 14,5	68,65	75,30	86,54	85,74			
G 3/4-14h.	26,441	24,50	D 140 x 28 x 20 x 16,0	86,23	94,90	108,80	107,78	136,10	169,99	
G 7/8-14h.	30,201	28,25	D 150 x 28 x 22 x 18,0	115,91	127,53	146,33	144,96			
G 1"-11h.	33,249	30,75	D 160 x 30 x 25 x 20,0	133,84	147,20	167,06	165,51			
G 1.1/8-11h.	37,897	35,50	D 170 x 30 x 28 x 22,0	213,72	243,82		267,79			
G 1.1/4-11h.	41,910	39,50	D 170 x 30 x 32 x 24,0	250,78	275,96		305,50			
G 1.3/8-11h.	44,323	42,00	D 180 x 32 x 36 x 29,0	313,62			424,35			
G 1.1/2-11h.	47,803	45,25	D 190 x 32 x 36 x 29,0	399,88	557,44		552,31			
G 1.3/4-11h.	53,746	51,25	D 190 x 32 x 40 x 32,0	475,30						
G 2"-11h.	59,614	57,00	D 220 x 36 x 45 x 35,0	606,20						

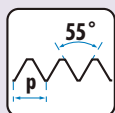
* Disponibles también con rosca izquierda con 100% de recargo sobre los precios tarifados en rosca derecha

BSF

HSSCo
5%
TOL
ISO 228
Vc
12 m/min
D
MANGO
DELGADO
DIN
5156

		D1 mm		L1 x L2 x D2 x ∇ mm	M1D	M2D	M3D	M4D
					FORMA C	FORMA B	15°	35°
					€	€	€	€
BSF 3/16-32h.	4,762	4,00	R 70 x 16 x 3,5 x 2,7	64,01				
BSF 1/4-26h.	6,350	5,20	D 80 x 17 x 4,5 x 3,4	28,01				
BSF 5/16-22h.	7,938	6,60	D 90 x 20 x 6,0 x 4,9	33,26				
BSF 3/8-20h.	9,525	8,10	D 100 x 22 x 7,0 x 5,5	34,97				
BSF 7/16-18h.	11,113	9,50	D 100 x 22 x 8,0 x 6,2	47,12				
BSF 1/2-16h.	12,700	11,00	D 110 x 24 x 9,0 x 7,0	53,33				
BSF 9/16-16h.	14,287	12,50	D 110 x 25 x 11,0 x 9,0	56,44				
BSF 5/8-14h.	15,876	14,00	D 110 x 27 x 12,0 x 9,0	75,23				
BSF 3/4-12h.	19,051	16,50	D 125 x 30 x 14,0 x 11,0	89,05				
BSF 7/8-11h.	22,226	19,50	D 140 x 32 x 18,0 x 14,5	123,77				
BSF 1"-10h.	25,400	22,50	D 160 x 36 x 18,0 x 14,5	143,87				

MACHOS PARA ROSCAR A MÁQUINA HSSCo

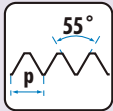
BSW



HSSCo
5%

TOL
Clase 2

Vc
12 m/min

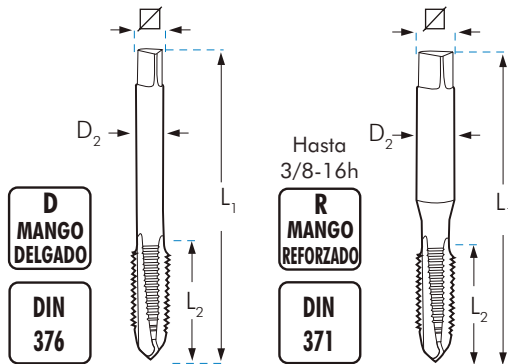

Icono	D1 mm	D	L1 x L2 x D2 x ∇ mm	M1R	M2R	M3R	M4R
				FORMA C	FORMA B	15°	35°
				€	€	€	€
W 1/16-60h.	1,59	1,15	R 40 x 8 x 2,5 x 2,1				
W 3/32-48h.	2,38	1,80	R 50 x 9 x 2,8 x 2,1	18,59	20,36		
W 1/8-40h.	3,17	2,55	R 56 x 11 x 3,5 x 2,7	15,51*	17,14	20,39	19,47
W 5/32-32h.	3,97	3,10	R 63 x 13 x 4,5 x 3,4	15,51	17,14	20,39	19,47
W 3/16-24h.	4,76	3,60	R 70 x 15 x 6,0 x 4,9	17,21	17,14	20,39	19,47
W 7/32-24h.	5,56	4,40	R 80 x 16 x 6,0 x 4,9	23,55	26,04		
W 1/4-20h.	6,35	5,10	R 80 x 17 x 7,0 x 5,5	16,57	19,47	23,15	22,93
W 5/16-18h.	7,94	6,50	R 90 x 20 x 8,0 x 6,2	19,43	23,66	27,01	26,27
W 3/8-16h.	9,52	7,90	R 100 x 22 x 10,0 x 8,0	20,79	26,15	30,02	29,19

MANGO DELGADO				M1D	M2D	M3D	M4D
W 7/16-14h.	11,11	9,25	D 100 x 22 x 8,0 x 6,2	30,24	29,89	38,55	37,83
W 1/2-12h.	12,70	10,50	D 110 x 24 x 9,0 x 7,0	29,00	30,59	36,94	36,25
W 9/16-12h.	14,29	12,00	D 110 x 26 x 11,0 x 9,0	41,57	43,17	52,97	51,98
W 5/8-11h.	15,87	13,40	D 110 x 27 x 12,0 x 9,0	39,36	40,79	50,09	49,15
W 11/16-11h.	17,46	15,25	D 110 x 27 x 12,0 x 9,0				
W 3/4-10h.	19,05	16,50	D 125 x 30 x 14,0 x 11,0	52,67	54,67	67,11	65,86
W 7/8-9h.	22,22	19,25	D 140 x 32 x 18,0 x 14,5	71,35	73,99	90,84	89,15
W 1"-8h.	25,40	21,75	D 160 x 36 x 18,0 x 14,5	89,67	92,99	114,00	111,87
W 1.1/8-7h.	28,57	24,75	D 180 x 40 x 22,0 x 18,0	116,28	135,98	163,51	
W 1.1/4-7h.	31,75	27,75	D 180 x 40 x 22,0 x 18,0	168,92	197,58		
W 1.3/8-6h.	34,92	30,50	D 200 x 50 x 28,0 x 22,0	277,65	324,46		
W 1.1/2-6h.	38,10	33,50	D 200 x 50 x 32,0 x 24,0	301,37	352,50		
W 1.5/8-5h.	41,27	46,50	D 220 x 65 x 32,0 x 24,0	420,65	492,04		
W 1.3/4-5h.	44,45	39,00	D 220 x 58 x 36,0 x 29,0	462,43	530,82		
W 1.7/8-4,5h.	47,62	42,00	D 250 x 75 x 36,0 x 29,0	512,68	588,47		
W 2"-4,5h.	50,80	44,50	D 250 x 65 x 40,0 x 32,0	661,84			
W 2.1/4-4h.	57,15	50,00					
W 2.1/2-4h.	63,50	56,50					
W 2.3/4-3,5h.	69,85	62,00					
W 3"-3,5h.	76,20	68,00					

* Disponibles también con rosca izquierda con 100% de recargo sobre los precios tarifados en rosca derecha

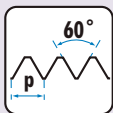
MACHOS PARA ROSCAR A MÁQUINA HSSCo
UNJC

HSSCo
5%

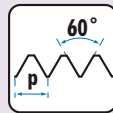
TOL
3B

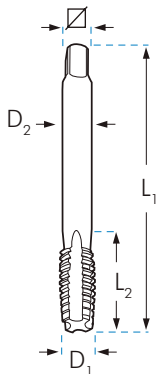
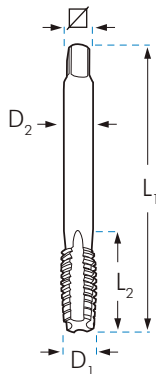
UNJF

HSSCo
5%

TOL
3B

Vc
12 m/min

Vc
12 m/min



		D1 mm		L1 x L2 x D2 x ∇ mm	M1R
					FORMA C
					€
UNJC nº 4-40h	2,84	2,25	R	56 x 11 x 3,5 x 2,7	25,93
UNJC nº 5-40h	3,17	2,60	R	56 x 11 x 3,5 x 2,7	25,93
UNJC nº 6-32h	3,50	2,75	R	56 x 12 x 4,0 x 3,0	24,67
UNJC nº 8-32h	4,17	3,50	R	63 x 13 x 4,5 x 3,4	24,67
UNJC nº10-24h	4,83	3,90	R	70 x 15 x 6,0 x 4,9	25,93
UNJC nº12-24h	5,49	4,50	R	80 x 16 x 6,0 x 4,9	27,20
UNJC 1/4-20h	6,35	5,10	R	80 x 17 x 7,0 x 5,5	15,32
UNJC 5/16-18h	7,94	6,60	R	90 x 20 x 8,0 x 6,2	17,66

		D1 mm		L1 x L2 x D2 x ∇ mm	M1R
					FORMA C
					€
UNJF nº 4-48h	2,84	2,35	R	56 x 11 x 3,5 x 2,7	28,44
UNJF nº 5-44h	3,17	2,70	R	56 x 11 x 3,5 x 2,7	28,44
UNJF nº 6-40h	3,50	2,95	R	56 x 12 x 4,0 x 3,0	27,20
UNJF nº 8-36h	4,17	3,50	R	63 x 13 x 4,5 x 3,4	27,20
UNJF nº10-32h	4,83	4,10	R	70 x 15 x 6,0 x 4,9	27,20
UNJF nº12-28h	5,49	4,60	R	80 x 16 x 6,0 x 4,9	28,44
UNJF 1/4-28h	6,35	5,50	R	80 x 17 x 7,0 x 5,5	15,32
UNJF 5/16-24h	7,94	6,90	R	90 x 20 x 8,0 x 6,2	17,66

MANGO DELGADO PASOS NORMALES				M1D
UNJC 3/8-16h	9,52	8,00	D 100 x 22 x 8,0 x 6,2	33,03
UNJC 7/16-14h	11,11	9,40	D 110 x 24 x 9,0 x 7,0	43,04
UNJC 1/2-13h	12,70	10,75	D 110 x 26 x 11,0 x 9,0	46,72
UNJC 9/16-12h	14,28	12,20	D 110 x 27 x 12,0 x 9,0	64,21
UNJC 5/8-11h	15,87	13,50	D 110 x 27 x 12,0 x 9,0	62,39
UNJC 3/4-10h	19,05	16,50	D 125 x 30 x 14,0 x 11,0	82,59
UNJC 7/8-9h	22,22	19,50	D 140 x 32 x 18,0 x 14,5	108,67
UNJC 1"-8h	25,40	22,25	D 160 x 36 x 18,0 x 14,5	143,58

MANGO DELGADO PASOS NORMALES				M1D
UNJF 3/8-24h	9,52	8,50	D 90 x 16 x 7,0 x 5,5	30,61
UNJF 7/16-20h	11,11	9,90	D 100 x 22 x 8,0 x 6,2	37,13
UNJF 1/2-20h	12,70	11,50	D 100 x 22 x 9,0 x 7,0	39,54
UNJF 9/16-18h	14,29	12,90	D 100 x 22 x 11,0 x 9,0	48,58
UNJF 5/8-18h	15,87	14,50	D 100 x 22 x 12,0 x 9,0	54,69
UNJF 3/4-16h	19,05	17,50	D 110 x 25 x 14,0 x 11,0	69,97
UNJF 7/8-14h	22,22	20,40	D 125 x 25 x 18,0 x 14,5	87,99
UNJF 1"-12h	25,40	23,25	D 140 x 28 x 18,0 x 14,5	119,19

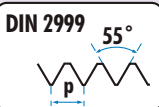
MACHOS PARA ROSCAR A MÁQUINA HSSCo

BSPP  **HSSCo 5%** **DIN 374** **FORMA C**

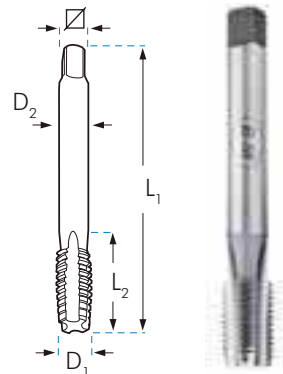

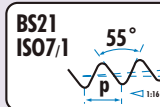

ROSCA CILÍNDRICA INGLESA PARA TUBO

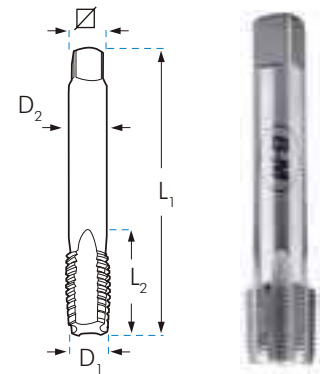
BSPT  **HSSCo 5%** **DIN 5156** **FORMA C**



ROSCA CÓNICA INGLESA PARA TUBO

	D1 mm	L1 x L2 x D2 x ∇ mm	M1D	€
Rp 1/16-28h.	7,72	D 90 x 16 x 6 x 4,9		
Rp 1/8-28h.	9,73	D 90 x 16 x 7 x 5,5		40,97
Rp 1/4-19h.	13,16	D 100 x 22 x 11 x 9,0		56,59
Rp 3/8-19h.	16,66	D 100 x 22 x 12 x 9,0		67,76
Rp 1/2-14h.	20,95	D 125 x 25 x 16 x 12,0		85,64
Rp 3/4-14h.	26,44	D 140 x 28 x 20 x 16,0		134,10
Rp 1"-11h.	33,25	D 160 x 30 x 25 x 20,0		208,06
Rp 1.1/4-11h.	41,91	D 170 x 30 x 32 x 24,0		
Rp 1.1/2-11h.	46,80	D 190 x 32 x 36 x 29,0		
Rp 2"-11h.	59,61	D 220 x 36 x 45 x 35,0		

	D1 mm	∇	L1 x L2 x D2 x ∇ mm	M1D	€
Rc 1/16-28h.	7,72		D 90 x 14 x 6 x 4		
Rc 1/8-28h.	9,73	8,30	D 90 x 15 x 7 x 5		42,72
Rc 1/4-19h.	13,16	11,00	D 100 x 19 x 11 x 9		61,43
Rc 3/8-19h.	16,66	14,50	D 100 x 21 x 12 x 9		85,38
Rc 1/2-14h.	20,95	18,10	D 125 x 26 x 16 x 12		118,63
Rc 5/8-14h.	22,91	21,00	D 140 x 36 x 18 x 19		187,79
Rc 3/4-14h.	26,44	23,50	D 140 x 28 x 20 x 16		185,02
Rc 7/8-14h.	30,20	28,25	D 160 x 36 x 22 x 18		321,97
Rc 1"-11h.	33,25	29,60	D 160 x 33 x 25 x 20		265,18

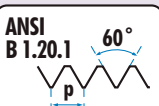
NPS (M)  **HSSCo 5%** **DIN 374** **FORMA C**

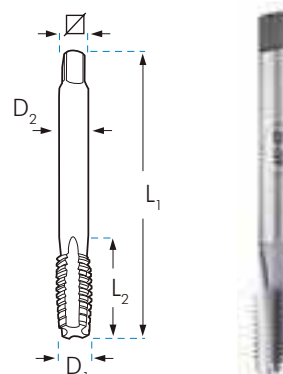

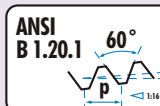

ROSCA CILÍNDRICA AMERICANA PARA TUBO

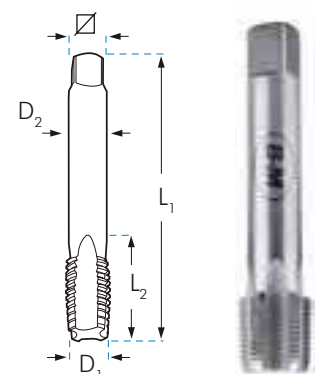
NPT  **HSSCo 5%** **DIN 374** **FORMA C**



ROSCA CÓNICA AMERICANA PARA TUBO

	D1 mm	∇	L1 x L2 x D2 x ∇ mm	M1D	€
NPS 1/8-27h.	10,20	8,90	D 90 x 16 x 7 x 5,5		107,54
NPS 1/4-18h.	13,60	11,70	D 100 x 22 x 11 x 9,0		153,91
NPS 3/8-18h.	17,00	15,00	D 100 x 22 x 12 x 9,0		211,06
NPS 1/2-14h.	21,20	18,60	D 125 x 25 x 16 x 12,0		289,42
NPS 3/4-14h.	26,55	24,00	D 140 x 28 x 20 x 16,0		427,85
NPS 1"-11,5 h.	33,20	30,00	D 160 x 30 x 25 x 20,0		553,29
NPS 1.1/4-11,5h.	41,60		D 170 x 30 x 32 x 24,0		
NPS 1.1/2-11,5h.	47,68		D 190 x 32 x 36 x 29,0		
NPS 2"-11,5h.	59,71		D 220 x 36 x 45 x 35,0		

	D1 mm	∇	L1 x L2 x D2 x ∇ mm	M1D	€
NPT 1/16-27h.	7,89	6,2	D 90 x 14 x 6 x 5		36,04
NPT 1/8-27h.	10,24	8,5	D 90 x 15 x 8 x 6		36,04
NPT 1/4-18h.	13,62	11,0	D 100 x 19 x 11 x 9		50,53
NPT 3/8-18h.	17,05	14,5	D 100 x 21 x 12 x 9		64,95
NPT 1/2-14h.	21,22	17,8	D 125 x 26 x 16 x 12		84,50
NPT 3/4-14h.	26,57	23,0	D 140 x 28 x 20 x 16		130,92
NPT 1"-11,5h.	33,23	29,0	D 160 x 33 x 25 x 20		170,16
NPT 1.1/4-11,5h.	41,98	37,5	D 170 x 36 x 32 x 24		223,81
NPT 1.1/2-11,5h.	48,05	44,0	D 190 x 37 x 36 x 29		365,84
NPT 2"-11,5h.	60,09	56,0	D 220 x 41 x 45 x 35		573,85

MACHOS PARA ROSCAR A MÁQUINA HSSCo

NPSF HSSCo 5% DIN 374 FORMA C

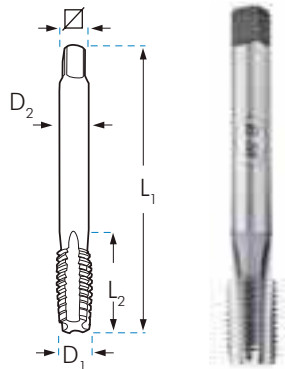
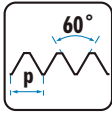

ROSCA PARA TUBO AMERICANA CILÍNDRICA

		D ₁ mm		L ₁ x L ₂ x D ₂ x	M1D
			∅	mm	€
NPSF	1/8-27h.	10,05	8,75	D 90 x 16 x 7 x 5,5	132,19
NPSF	1/4-18h.	13,33	11,30	D 100 x 22 x 11 x 9,0	182,20
NPSF	3/8-18h.	16,78	14,70	D 100 x 22 x 12 x 9,0	259,20
NPSF	1/2-14h.	20,87	18,20	D 125 x 25 x 16 x 12,0	323,23
NPSF	3/4-14h.	26,23	23,50	D 140 x 28 x 20 x 16,0	529,01
NPSF	1"-11,5h.	32,81	29,50	D 160 x 30 x 25 x 20,0	

NPTF HSSCo 5% DIN 374 FORMA C

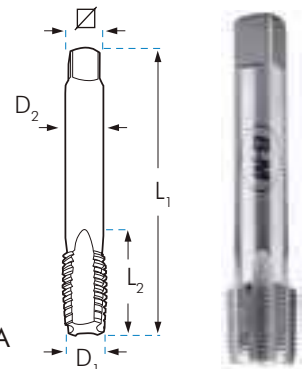
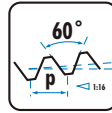

ROSCA PARA TUBO AMERICANA CÓNICA ESTANCA

		D ₁ mm		L ₁ x L ₂ x D ₂ x	M1D
			∅	mm	€
NPTF	1/16-27h.	7,87	6,20	D 90 x 14 x 12,0 x 6	
NPTF	1/8-27h.	10,22	8,50	D 90 x 15 x 12,0 x 7	89,31
NPTF	1/4-18h.	13,58	11,00	D 100 x 21 x 17,5 x 11	125,29
NPTF	3/8-18h.	17,02	14,50	D 110 x 21 x 17,6 x 12	160,96
NPTF	1/2-14h.	21,21	17,80	D 140 x 27 x 22,8 x 16	209,54
NPTF	3/4-14h.	26,56	23,00	D 140 x 27 x 23,0 x 20	324,62

MF HSSCo 5% TOL 6H FORMA C DIN 374

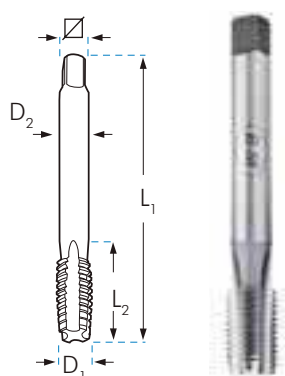
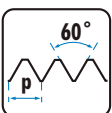

ROSCA MÉTRICA FINA PARA TUBO DE CONDUCCIÓN ELÉCTRICA EN 60423

		D ₁ mm		L ₁ x L ₂ x D ₂ x	M1D
			∅	mm	€
MF	12 x 1,50	12	10,5	D 100 x 22 x 9 x 7,0	21,35
MF	16 x 1,50	16	14,5	D 100 x 22 x 12 x 9,0	30,07
MF	20 x 1,50	20	18,5	D 125 x 25 x 16 x 12,0	45,09
MF	25 x 1,50	25	23,5	D 140 x 28 x 18 x 14,5	103,85
MF	32 x 1,50	32	30,5	D 150 x 28 x 22 x 18,0	129,62
MF	40 x 1,50	40	38,5	D 170 x 30 x 32 x 24,0	226,26
MF	50 x 1,50	50	48,5	D 190 x 32 x 36 x 29,0	339,91
MF	63 x 1,50	63	61,5	D 275 x 36 x 50 x 39,0	

PG HSSCo 5% DIN 40430 FORMA C

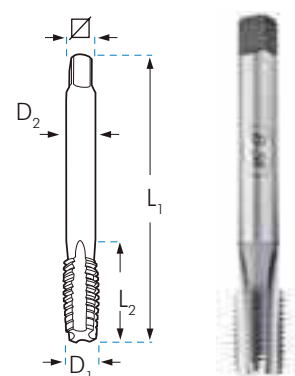
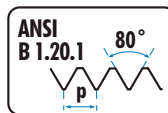

ROSCA PARA TUBO DE CONDUCCIÓN ELÉCTRICA

		D ₁ mm		L ₁ x L ₂ x D ₂ x	M1D
			∅	mm	€
PG	7 - 20h.	12,5	11,50	D 100 x 22 x 9 x 7,0	39,19
PG	9 - 18h.	15,2	14,00	D 100 x 22 x 12 x 9,0	54,27
PG	11 - 18h.	18,6	17,25	D 110 x 25 x 14 x 11,0	70,62
PG	13,5 - 18h.	20,4	19,00	D 125 x 25 x 16 x 12,0	79,30
PG	16 - 18h.	22,5	21,25	D 125 x 25 x 18 x 14,5	93,33
PG	21 - 16h.	28,3	27,00	D 150 x 28 x 22 x 18,0	148,16
PG	29 - 16h.	37,0	35,50	D 170 x 30 x 28 x 22,0	250,47
PG	36 - 16h.	47,0	45,50	D 190 x 32 x 36 x 29,0	406,77
PG	42 - 16h.	54,0	52,50	D 190 x 32 x 40 x 32,0	646,03
PG	48 - 16h.	59,3	58,00	D 220 x 36 x 45 x 35,0	787,56

MACHOS PARA ROSCAR A MÁQUINA HSSCo

UNx8 HSSCo 5% DIN 374 FORMA C TOL 2B

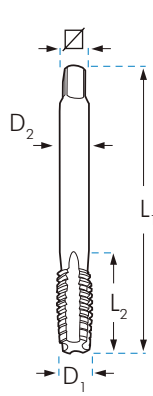
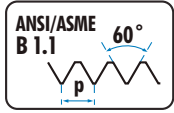

UNEF HSSCo 5% DIN 374 TOL 2B

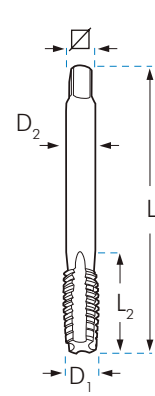
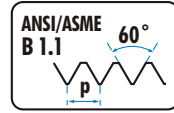

				M1D
		D2 mm	L1 x L2 x ∇ mm	€
UN 1" 1/8-8h.	25,40	22	180 x 45 x 18	229,08
UN 1" 1/4-8h.	28,50	22	180 x 48 x 18	295,54
UN 1" 3/8-8h.	31,75	28	200 x 56 x 22	335,26
UN 1" 1/2-8h.	35,00	32	200 x 58 x 22	400,17
UN 1" 5/8-8h.	38,10	32	200 x 65 x 24	468,10
UN 1" 3/4-8h.	41,25	36	200 x 50 x 29	570,23
UN 1" 7/8-8h.	44,45	36	225 x 53 x 29	638,03
UN 2"-8h.	47,63	40	225 x 50 x 32	672,08

				M2D	M4D
		D2 mm	L1 x L2 x ∇ mm	FORMA B €	35° €
UNEF 1/4-32h.	5,55	7,0	R 82 x 16 x 5,4	80,61	90,59
UNEF 5/16-32h.	7,15	8,4	R 85 x 21 x 6,1	88,82	99,80
UNEF 3/8-32h.	8,70	7,0	D 95 x 22 x 5,4	88,87	99,85
UNEF 7/16-28h.	10,20	8,0	D 100 x 22 x 6,2	117,96	132,54
UNEF 1/2-28h.	11,80	9,0	D 100 x 22 x 7,0	124,25	139,60
UNEF 9/16-24h.	13,20	12,0	D 100 x 24 x 9,0	155,66	174,90
UNEF 5/8-24h.	14,80	12,0	D 100 x 24 x 9,0	177,13	199,03
UNEF 3/4-20h.	17,80	14,0	D 110 x 27 x 11,0	230,38	258,87
UNEF 7/8-20h.	20,95	18,0	D 125 x 26 x 14,5	247,64	265,33
UNEF 1"-20h.	24,20	18,0	D 140 x 28 x 14,5	378,97	425,81

MACHOS MÁQUINA MÉTRICA NORMA ISO 529

M MF HSSCo 5% ISO 529 TOL 6H

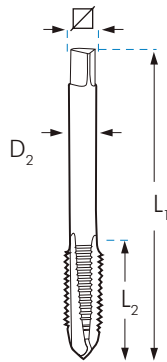
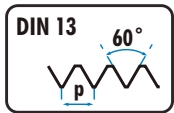

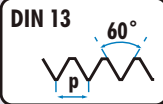

				M2RISO	M4RISO	M5RISO
			L1 x L2 x D2 x ∇ mm	FORMA B €	35° €	DIENTE ALTERNO AI €
M 3x0,50	2,50	R	48 x 11 x 3,15 x 2,50	6,89	8,30	8,95
M 4x0,70	3,30	R	53 x 13 x 4,00 x 3,15	6,89	8,30	8,95
M 5x0,80	4,20	R	58 x 16 x 5,00 x 4,00	6,89	8,30	8,95
M 6x1,00	5,00	R	66 x 19 x 6,30 x 5,00	6,89	8,48	8,95
M 8x1,25	6,75	R	72 x 22 x 8,00 x 6,30	9,20	9,51	9,78
M 10x1,50	8,50	R	80 x 24 x 10,00 x 8,00	11,70	12,26	12,34
MANGO DELGADO				M2DISO	M4DISO	M5DISO
M 12x1,75	10,20	D	89 x 29 x 9,00 x 7,10	15,04	15,93	18,46
M 14x2,00	12,00	D	95 x 30 x 11,20 x 9,00	17,98	21,77	
M 16x2,00	14,00	D	102 x 32 12,50 x 10,00	22,33	25,25	
M 18x2,50	15,50	D	112 x 37 x 14,00 x 11,20	33,62	42,03	
M 20x2,50	17,50	D	112 x 37 x 14,00 x 11,20	37,58	46,97	
M 22x2,50	19,50	D	118 x 38 x 16,00 x 12,50	43,45	54,32	
M 24x3,00	21,00	D	130 x 45 x 18,00 x 14,00	49,09	61,36	
M 27x3,00	24,00	D	135 x 45 x 20,00 x 16,00	60,45	75,56	
M 30x3,50	26,50	D	138 x 48 x 20,00 x 16,00	89,81	112,26	

MACHOS DE MÁQUINA Y COJINETES SERIE Plus
Plus

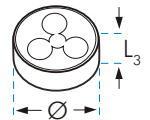
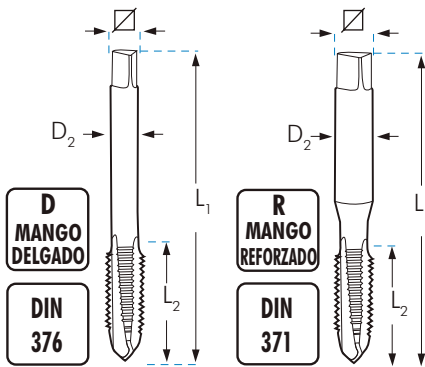
**TOL
6H**

 PARA TRABAJOS DE ALTA PRODUCCIÓN
 FABRICADOS EN ACERO SINTERIZADO

**DIN
22568**
**TOL
6g**
**Vc
14 m/min**
**Vc
16 m/min**
**Vc
17 m/min**

		M2RP	M4RP	M2RT	M4RT	M2RHL	M4RHL	C5P			
CALIDAD		★★	★★	★★★★	★★★★	★★★★	★★★★				
MATERIAL		HSS PM	HSS PM	HSSCo 5%	HSSCo 5%	HSS PM	HSS PM	HSS			
ACABADO		BRILLANTE	BRILLANTE	TiN	TiN	HARD LUBE	HARD LUBE	BRILLANTE			
ÁNGULO DE HÉLICE		FORMA B	35°	FORMA B	35°	FORMA B	35°				
		L1 x L2 x D2 x ∇ mm	€	€	€	€	€	€	€		
M	3x0,50	2,50	R 56 x 11 x 3,5 x 2,7	12,82*	15,84	17,91	19,79	24,43	25,97	25 x 9	25,41
M	4x0,70	3,30	R 63 x 13 x 4,5 x 3,4	13,09*	15,84	18,20	20,65	24,35	26,33	25 x 9	25,41
M	5x0,80	4,20	R 70 x 16 x 6,0 x 4,9	13,09*	15,18	18,20	20,53	23,80	26,33	25 x 9	25,41
M	6x1,00	5,00	R 80 x 17 x 6,0 x 4,9	14,40*	16,67	20,95	22,69	26,74	27,87	25 x 9	25,41
M	8x1,00	7,00	D 90 x 20 x 6,0 x 4,9	20,55	24,38	28,94	32,20	39,07	43,48	25 x 9	34,13
M	8x1,25	6,75	R 90 x 20 x 8,0 x 6,2	16,13*	19,02	24,50	26,64	32,75	33,34	25 x 9	26,55
M	10x1,00	9,00	D 90 x 16 x 7,0 x 5,5	22,91	28,73	33,80	38,81	45,62	53,90	38 x 10	41,71
M	10x1,50	8,50	R 100 x 22 x 10,0 x 8,0	19,83*	22,55	28,85	31,59	40,61	41,49	38 x 10	37,89
MANGO DELGADO											
M	12x1,50	10,50	D 100 x 22 x 9,0 x 7,0	27,18	32,86	36,63	41,24	52,01	59,66	38 x 10	44,59
M	12x1,75	10,20	D 110 x 24 x 9,0 x 7,0	25,56	30,36	34,93	39,39	46,19	55,43	38 x 14	39,37
M	14x1,50	12,50	D 100 x 22 x 11,0 x 9,0	32,20	40,38	43,08	48,48	61,18	70,15	38 x 10	46,62
M	14x2,00	12,00	D 110 x 26 x 11,0 x 9,0	31,96	37,05	43,11	47,39	61,82	67,95	38 x 14	40,13
M	16x1,50	14,50	D 100 x 22 x 12,0 x 9,0	40,28	49,67	51,77	59,20	57,17	70,51	45 x 14	64,03
M	16x2,00	14,00	D 110 x 27 x 12,0 x 9,0	37,58	44,78	49,22	54,41	70,58	78,01	45 x 18	53,91
M	18x2,50	15,50	D 125 x 30 x 14,0 x 11,0	53,28	60,19	64,74	70,63	91,91	100,27	45 x 18	53,91
M	20x2,50	17,50	D 140 x 32 x 16,0 x 12,0	57,56	64,16	73,79	79,50	104,76	112,89	45 x 18	53,91
M	22x2,50	19,50	D 140 x 32 x 18,0 x 14,5	69,64	79,17	84,95	92,66	122,87	134,08	55 x 22	80,90
M	24x3,00	21,00	D 160 x 34 x 18,0 x 14,5	82,80	94,78	95,72	105,99	138,45	153,36	55 x 22	80,90

* Disponibles también con rosca izquierda con 100% de recargo sobre los precios tarifados en rosca derecha

MACHOS DE MÁQUINA PARA TRABAJOS ESPECIALES HSS-PM

INOX

M

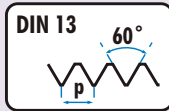

TOL
6H

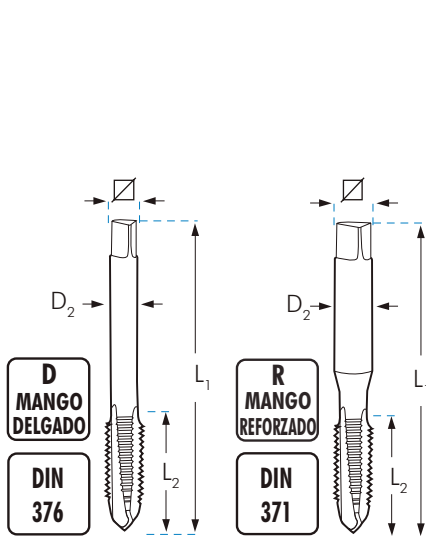

Vc
6 m/min

Vc
10 m/min



Vc
12 m/min

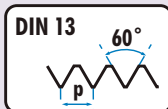
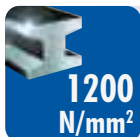
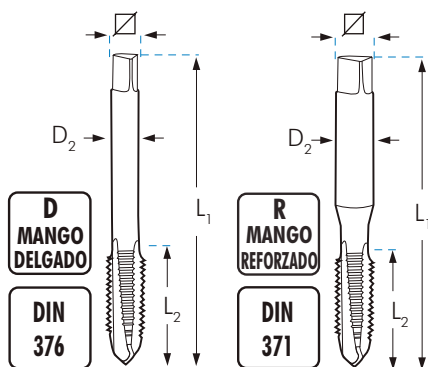

			M2RX	M4RX	M2RXT	M4RXT	M2RXHL	M4RXHL
CALIDAD			★★	★★	★★★	★★★	★★★★	★★★★
MATERIAL			HSS PM	HSS PM	HSSCo 5%	HSSCo 5%	HSS PM	HSS PM
ACABADO			OX	OX	TiN	TiN	HARD LUBE	HARD LUBE
ÁNGULO DE HÉLICE			FORMA B	35°	FORMA B	35°	FORMA B	35°
		L ₁ x L ₂ x D ₂ x	€	€	€	€	€	€
M 3x0,50	2,50	R 56 x 11 x 3,5 x 2,7	15,21	18,72	16,92	19,69	23,23	27,32
M 4x0,70	3,30	R 63 x 13 x 4,5 x 3,4	15,97	18,72	17,75	20,01	24,40	28,04
M 5x0,80	4,20	R 70 x 16 x 6,0 x 4,9	15,97	17,90	17,75	20,31	24,40	28,46
M 6x1,00	5,00	R 80 x 17 x 6,0 x 4,9	17,50	19,69	19,15	21,24	26,72	29,78
M 8x1,25	6,75	R 90 x 20 x 8,0 x 6,2	19,52	22,44	22,13	24,47	29,84	34,29
M 10x1,50	8,50	R 100 x 22 x 10,0 x 8,0	23,87	26,62	25,87	28,86	36,45	40,66

MANGO DELGADO			M2DX	M4DX	M2DXT	M4DXT	M2DXHL	M4DXHL
M 12x1,75	10,20	D 110 x 24 x 9,0 x 7,0	30,67	35,91	33,41	37,61	46,00	53,85
M 14x2,00	12,00	D 110 x 26 x 11,0 x 9,0	43,66	47,93	43,94	47,05	61,13	67,69
M 16x2,00	14,00	D 110 x 27 x 12,0 x 9,0	48,62	55,32	47,79	54,99	68,06	81,87
M 18x2,50	15,50	D 125 x 30 x 14,0 x 11,0	72,82	78,71	75,18	78,27	109,21	116,48
M 20x2,50	17,50	D 140 x 32 x 16,0 x 12,0	78,69	83,12	78,37	82,63	116,10	122,99
M 22x2,50	19,50	D 140 x 32 x 18,0 x 14,5			102,94	111,45		
M 24x3,00	21,00	D 160 x 34 x 18,0 x 14,5			114,06	123,91		

MACHOS DE MÁQUINA PARA TRABAJOS ESPECIALES HSS-V3

**HSS
V3**
**TOL
6H**
**MATERIALES
DUROS**

**Vc
7
m/min**
**Vc
9
m/min**

		M2RMD	M4RMD	M2RMDTX	M4RMDTX		
CALIDAD		★★★	★★★	★★★★	★★★★		
MATERIAL		HSS V3	HSS V3	HSS V3	HSS V3		
ACABADO		OX	OX	TINALOX	TINALOX		
ÁNGULO DE HÉLICE		FORMA B	35°	FORMA B	35°		
			$L_1 \times L_2 \times D_2 \times \square$ mm	€	€	€	€
M 3x0,50	2,50	R 56 x 11 x 3,5 x 2,7	13,77	15,44	19,91	23,41	
M 4x0,70	3,30	R 63 x 13 x 4,5 x 3,4	14,31	15,81	20,92	24,51	
M 5x0,80	4,20	R 70 x 16 x 6,0 x 4,9	14,31	15,72	20,92	24,51	
M 6x1,00	5,00	R 80 x 17 x 6,0 x 4,9	15,68	17,29	22,91	25,77	
M 8x1,25	6,75	R 90 x 20 x 8,0 x 6,2	17,67	19,34	25,57	29,39	
M 10x1,50	8,50	R 100 x 22 x 10,0 x 8,0	20,36	22,38	32,36	36,09	
MANGO DELGADO		M2DMD	M4DMD	M2DMDTX	M4DMDTX		
M 12x1,75	10,20	D 110 x 24 x 9,0 x 7,0	28,01	30,63	41,59	48,69	
M 14x2,00	12,00	D 110 x 26 x 11,0 x 9,0	34,83	38,36	59,19	64,98	
M 16x2,00	14,00	D 110 x 27 x 12,0 x 9,0	41,10	46,40	65,93	78,59	
M 18x2,50	15,50	D 125 x 30 x 14,0 x 11,0	58,09	66,02	96,92	109,77	
M 20x2,50	17,50	D 140 x 32 x 16,0 x 12,0	62,78	69,70	104,75	115,87	

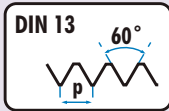
MACHOS DE MÁQUINA PARA TRABAJOS ESPECIALES TiCN

1400
N/mm²



TiCN

TOL
6H

HSS
PM

MATERIALES
MUY
DUROS

Vc
5 m/min

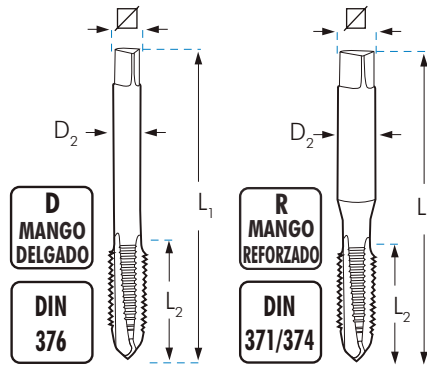

		M2RC	M3RC	
		FORMA B	15°	
		€	€	
M 3 x 0,50	2,50	R 56 x 11 x 3,5 x 2,7	24,27	25,82
M 4 x 0,70	3,30	R 63 x 13 x 4,5 x 3,4	25,21	27,50
M 5 x 0,80	4,20	R 70 x 16 x 6,0 x 4,9	25,45	26,87
M 6 x 1,00	5,00	R 80 x 17 x 6,0 x 4,9	26,54	31,22
M 8 x 1,25	6,75	R 90 x 20 x 8,0 x 6,2	30,66	34,98
M 10 x 1,00	9,00	D 90 x 16 x 7,0 x 5,5	43,23	48,27
M 10 x 1,50	8,50	R 100 x 22 x 10,0 x 8,0	36,70	43,34

		M2DC	M3DC	
M 12 x 1,75	10,20	D 110 x 24 x 9,0 x 7,0	45,74	59,16
M 14 x 1,50	12,50	D 100 x 22 x 11,0 x 9,0	54,45	62,02
M 14 x 2,00	12,00	D 110 x 26 x 11,0 x 9,0	54,49	60,19
M 16 x 2,00	14,00	D 110 x 27 x 12,0 x 9,0	61,48	69,14
M 18 x 2,50	15,50	D 125 x 30 x 14,0 x 11,0	77,85	85,66
M 20 x 2,50	17,50	D 140 x 32 x 16,0 x 12,0	91,13	99,16

MACHOS DE MÁQUINA PARA MATERIALES EXTREMADAMENTE DUROS FABRICADOS EN METAL DURO + TiCN

MD

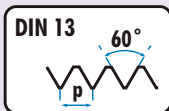

TiCN

TOL
6H

MATERIALES
48-62
HRc

R
MANGO
REFORZADO

DIN
371

D
MANGO
DELGADO

DIN
376



- Lubricación: **CUT MAGIC** XTHICK
- Se recomienda roscar la pieza sobre el mismo utillaje utilizado para el taladro previo y en la misma posición, para garantizar coaxialidad entre macho y orificio previo.

		M1RHMC	
		FORMA C	
		€	
M 5 x 0,80	4,30	R 70 x 16 x 6,0 x 4,9	248,78
M 6 x 1,00	5,10	R 80 x 17 x 6,0 x 4,9	248,78
M 8 x 1,25	6,90	R 90 x 20 x 8,0 x 6,2	280,00
M 10 x 1,50	8,60	R 100 x 22 x 10,0 x 8,0	358,02

		M1DHMC	
M 12 x 1,75	10,40	D 110 x 24 x 9,0 x 7,0	395,79

HRc	Vc (m/min)
48 Hrc	8 m/min
56 Hrc	6 m/min
62Hrc	3 m/min

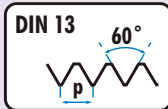
MACHOS DE MÁQUINA TODO TERRENO
**TODO
TERRENO**

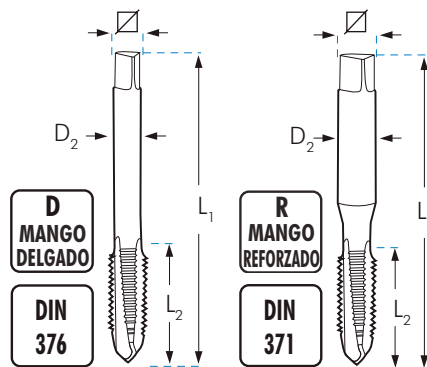
**HSSCo
5%**
TiN
**TOL
6H**
APLICACIONES
Al

**1200
N/mm²**
FUNDICIÓN
Ti
INOX
**Vc
13
m/min**

				M2RD	M4RD
			$L_1 \times L_2 \times D_2 \times \square$ mm	FORMA B €	 €
M 3 x 0,50	2,50	R	56 x 11 x 3,5 x 2,7	22,84	26,68
M 4 x 0,70	3,30	R	63 x 13 x 4,5 x 3,4	22,84	26,68
M 5 x 0,80	4,20	R	70 x 16 x 6,0 x 4,9	24,30	27,64
M 6 x 1,00	5,00	R	80 x 17 x 6,0 x 4,9	25,15	28,69
M 8 x 1,25	6,75	R	90 x 20 x 8,0 x 6,2	29,46	32,74
M 10 x 1,50	8,50	R	100 x 22 x 10,0 x 8,0	33,99	38,78

				M2DD	M4DD
		MANGO DELGADO			
M 12 x 1,75	10,20	D	110 x 24 x 9,0 x 7,0	42,83	50,99
M 14 x 2,00	12,00	D	110 x 26 x 11,0 x 9,0	55,94	61,47
M 16 x 2,00	14,00	D	110 x 27 x 12,0 x 9,0	62,68	67,84
M 18 x 2,50	15,50	D	125 x 30 x 14,0 x 11,0	97,95	100,44
M 20 x 2,50	17,50	D	140 x 32 x 16,0 x 12,0	99,77	103,51

MACHOS DE MÁQUINA PARA TRABAJOS ESPECIALES HSSCo

Al
FUNDICIÓN
LATÓN

DIN 13 60°

HSSCo
5%

TOL
6H

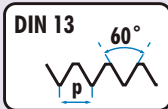

		M5R	M6R	M1RFM	MHM1R	M1RL	M1RLCRN
APLICACIÓN		Al	Al	FUNDICIÓN	FUNDICIÓN	LATÓN	LATÓN
MATERIAL		HSSCo 5%	HSSCo 5%	HSSCo 5%	MD	HSSCo 5%	HSSCo 5%
ACABADO		BRILLANTE	BRILLANTE	OX	BRILLANTE	BRILLANTE	CrN
FORMA		DIENTE ALTERNO	2 CANALES	FORMA C	FORMA C	FORMA C	FORMA C
	$L_1 \times L_2 \times D_2 \times \square$ mm	€	€	€	€	€	€
M 3x0,50	2,50 R 56 x 11 x 3,5 x 2,7	18,77	19,40	13,28	61,46	15,90	18,06
M 4x0,70	3,30 R 63 x 13 x 4,5 x 3,4	18,87	19,40	13,73	61,46	16,88	19,90
M 5x0,80	4,20 R 70 x 16 x 6,0 x 4,9	18,77	19,81	13,73	61,46	16,88	19,98
M 6x1,00	5,00 R 80 x 17 x 6,0 x 4,9	19,78	21,42	15,59	70,10	18,50	21,82
M 8x1,25	6,75 R 90 x 20 x 8,0 x 6,2	23,68	25,67	17,46	78,27	21,09	26,53
M 10x1,50	8,50 R 100 x 22 x 10,0 x 8,0	28,55	30,36	19,97	98,09	25,37	32,28
MANGO DELGADO		M5D	M6D	M1DFM	MHM1D	M1DL	M1DLCRN
M 12x1,75	10,20 D 110 x 24 x 9,0 x 7,0	35,62	37,11	25,12	134,31	29,60	39,01
M 14x2,00	12,00 D 110 x 26 x 11,0 x 9,0	64,50	46,99	41,29	209,24	36,34	47,54
M 16x2,00	14,00 D 110 x 27 x 12,0 x 9,0	70,30	61,49	48,58	248,93	41,81	53,15
M 18x2,50	15,50 D 125 x 30 x 14,0 x 11,0			67,96	305,14	54,84	67,32
M 20x2,50	17,50 D 140 x 32 x 16,0 x 12,0			68,22	369,51	61,55	74,95

MACHOS DE MÁQUINA PARA ROSCADO POR LAMINACIÓN

HSSCo
5%

TOL
6HX

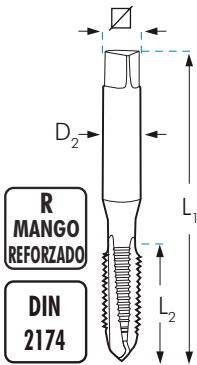

				M07R	M07RT	M07RCR	M07RTCR	M07RCCR
APLICACIÓN								
MATERIAL				HSSCo 5%	HSSCo 5%	HSSCo 5%	HSSCo 5%	HSSCo 5%
ACABADO				OX	TiN	OX	TiN	TiCN
FORMA								
		$L_1 \times L_2 \times D_2 \times \nabla$ mm		€	€	€	€	€
M 3x0,50	2,75	R 56 x 11 x 3,5 x 2,7		25,36	28,05	27,14	32,00	33,10
M 3,5x0,60	3,20	R 56 x 11 x 3,5 x 2,7		26,65	30,36	28,04	34,70	35,03
M 4x0,70	3,65	R 63 x 13 x 4,5 x 3,4		25,36	29,26	27,14	33,39	34,52
M 5x0,80	4,60	R 70 x 16 x 6,0 x 4,9		25,36	29,26	27,14	33,39	34,52
M 6x1,00	5,50	R 80 x 17 x 6,0 x 4,9		27,38	30,92	29,28	35,30	36,48
M 8x1,25	7,40	R 90 x 20 x 8,0 x 6,2		31,91	40,81	34,14	46,58	48,16
M 10x1,50	9,30	R 100 x 22 x 10,0 x 8,0		35,49	45,76	37,97	51,27	53,01

				M07D	M07DT	M07DCR	M07DTCR	M07DCCR
M 12x1,75	11,20	D 110 x 24 x 9,0 x 7,0		41,82	58,72	43,90	64,54	60,70
M 14x2,00	13,05	D 110 x 26 x 11,0 x 9,0		75,40	94,50	77,62	103,48	93,85
M 16x2,00	15,05	D 110 x 27 x 12,0 x 9,0		88,52	106,44	91,11	116,57	95,37
M 18x2,50	16,80	D 125 x 30 x 14,0 x 11,0		101,58	124,89	104,55	129,42	117,39
M 20x2,50	18,80	D 140 x 32 x 16,0 x 12,0		133,84	189,06	137,77	195,92	164,73

BROCA MACHO HSSCo

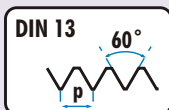

HSSCo
5%

BRILLANTE

TOL
6H

R
MANGO
REFORZADO

DIN
371

D
MANGO
DELGADO

DIN
376

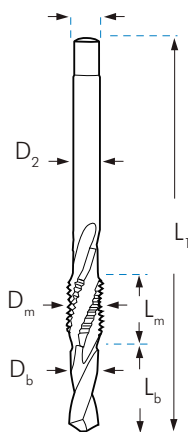

								M8M	
		L _b mm	L _m mm	L ₁ mm	D _b mm	D _m mm	D ₂ mm	∅ mm	€
M 3x0,50	R	9,0	12,5	62,0	2,50	3,0	3,5	2,7	30,20
M 4x0,70	R	10,0	16,0	66,0	3,30	4,0	4,5	3,4	30,20
M 5x0,80	R	12,5	18,0	75,5	4,20	5,0	6,0	4,9	31,38
M 6x1,00	R	14,0	20,0	81,0	5,00	6,0	6,0	4,9	34,66
M 8x1,00	R	20,0	14,0	91,0	7,00	8,0	6,0	4,9	39,93
M 8x1,25	R	20,0	14,0	91,0	6,75	8,0	8,0	6,2	42,20

MANGO DELGADO

		D	L ₁	L ₂	D ₂	∅	€		
M 8x1,25	D	20,0	14,0	91,0	6,75	8,0	6,0	4,9	42,20
M 10x1,00	D	20,0	15,0	95,0	9,00	10,0	7,0	5,5	49,57
M 10x1,50	D	25,0	18,0	105,0	8,50	10,0	7,0	5,5	53,59
M 12x1,50	D	24,0	18,0	110,0	10,50	12,0	9,0	7,0	57,42
M 12x1,75	D	28,0	20,0	118,0	10,20	12,0	9,0	7,0	58,15
M 14x1,50	D	28,0	20,0	118,0	12,50	14,0	11,0	9,0	90,86
M 14x2,00	D	28,0	22,0	130,0	12,00	14,0	11,0	9,0	103,35
M 18x2,50	D	40,0	26,0	151,0	15,50	18,0	14,0	11,0	198,25
M 20x2,50	D	45,0	30,0	168,0	17,50	20,0	16,0	12,0	284,70

Nota: Jamás emplee los Broca-Machos en agujeros ciegos o en pasantes más profundos que L_b

MACHO DE MÁQUINA ROSCA TRAPEZOIDAL HSS

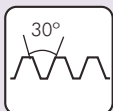

HSS

BRILLANTE



DIN
103

TOL
7H

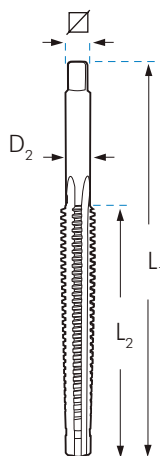

				MRTM
		∅	L ₁ x L ₂ x D ₂ x ∅ mm	€
Tr	14 x 3	11,25	160 x 105 x 10,5 x 8,0	474,47
Tr	16 x 4	12,25	205 x 110 x 11,5 x 9,0	493,94
Tr	18 x 4	14,25	215 x 120 x 13,0 x 10,0	520,69
Tr	20 x 4	16,25	230 x 130 x 15,0 x 12,0	523,13
Tr	22 x 5	17,25	270 x 165 x 16,0 x 12,0	688,59
Tr	24 x 5	19,25	280 x 165 x 18,0 x 14,5	781,06
Tr	26 x 5	21,25	290 x 170 x 20,0 x 16,0	808,15
Tr	28 x 5	23,25	300 x 180 x 22,0 x 18,0	915,46
Tr	30 x 6	24,25	345 x 200 x 23,0 x 18,0	1.053,56

MACHOS DE MÁQUINA EXTRALARGOS HSSCo

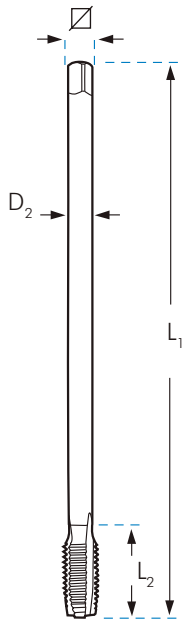
FORMA B**HSSCo
5%****BRILLANTE****TOL
6H****R
MANGO
REFORZADO****DIN
371****D
MANGO
DELGADO****DIN
376**

			M2L	
			$L_1 \times L_2 \times D_2 \times \nabla$ mm	FORMA B €
M	3x0,50	2,50	R 100 x 10 x 3,5 x 2,7	30,37
M	4x0,70	3,30	R 120 x 12 x 4,5 x 3,4	31,04
M	5x0,80	4,20	R 140 x 14 x 6,0 x 4,9	31,04
M	6x1,00	5,00	R 160 x 16 x 6,0 x 4,9	34,11
M	7x1,00	6,00	R 160 x 17 x 7,0 x 5,5	38,00
M	8x1,25	6,75	R 180 x 18 x 8,0 x 6,2	39,99

			M2L-D	
			$L_1 \times L_2 \times D_2 \times \nabla$ mm	€
M	6x1,00	5,00	D 160 x 16 x 4,5 x 3,4	34,74
M	8x1,25	6,75	D 180 x 18 x 6,2 x 5,0	40,75
M	10x1,50	8,50	D 200 x 20 x 7,0 x 5,5	49,23
M	12x1,75	10,20	D 220 x 22 x 8,5 x 6,5	60,57
M	14x2,00	12,00	D 220 x 25 x 10,5 x 8,0	92,21
M	16x2,00	14,00	D 220 x 28 x 12,5 x 10,0	108,47
M	18x2,50	15,50	D 250 x 32 x 14,0 x 11,0	197,36
M	20x2,50	17,50	D 250 x 32 x 16,0 x 12,0	213,32

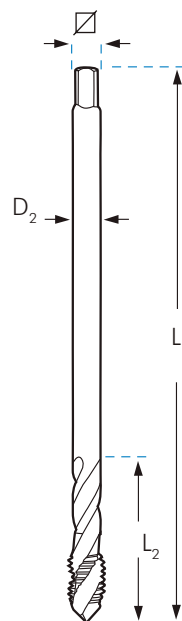
**35°****HSSCo
5%****BRILLANTE****TOL
6H****R
MANGO
REFORZADO****DIN
371****D
MANGO
DELGADO****DIN
376**

			M4L	
			$L_1 \times L_2 \times D_2 \times \nabla$ mm	35° €
M	3x0,50	2,50	R 100 x 10 x 3,5 x 2,7	37,58
M	4x0,70	3,30	R 120 x 12 x 4,5 x 3,4	37,58
M	5x0,80	4,20	R 140 x 14 x 6,0 x 4,9	36,00
M	6x1,00	5,00	R 160 x 16 x 6,0 x 4,9	39,50
M	7x1,00	6,00	R 160 x 17 x 7,0 x 5,5	43,98
M	8x1,25	6,75	R 180 x 18 x 8,0 x 6,2	47,99

			M4L-D	
			$L_1 \times L_2 \times D_2 \times \nabla$ mm	€
M	6x1,00	5,00	D 160 x 16 x 4,5 x 3,4	40,25
M	8x1,25	6,75	D 180 x 18 x 6,2 x 5,0	47,09
M	10x1,50	8,50	D 200 x 20 x 7,0 x 5,5	55,62
M	12x1,75	10,20	D 220 x 22 x 8,5 x 6,5	71,95
M	14x2,00	12,00	D 220 x 25 x 10,5 x 8,0	103,32
M	16x2,00	14,00	D 220 x 28 x 12,5 x 10,0	149,74
M	18x2,50	15,50	D 250 x 32 x 14,0 x 11,0	223,48
M	20x2,50	17,50	D 250 x 32 x 16,0 x 12,0	237,84

MACHO TUERQUERO DE ROSCA MÉTRICA DIN 357



- HSSCo
5%
- BRILLANTE
- TOL
6H
- DIN
357

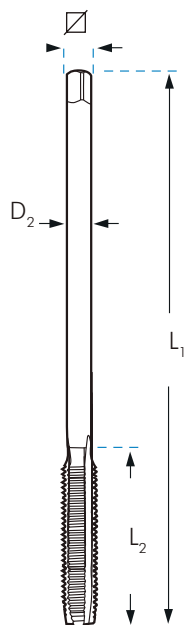

			MTU	
			FORMA	C
			€	
			$L_1 \times L_2 \times D_2 \times \nabla$ mm	
M	3x0,50*	2,50	D 70 x 22 x 2,2	20,45
M	4x0,70	3,30	D 90 x 25 x 2,8 x 2,1	20,45
M	5x0,80	4,20	D 100 x 28 x 3,5 x 2,7	20,45
M	6x1,00	5,00	D 110 x 32 x 4,5 x 3,4	20,45
M	8x1,25	6,80	D 125 x 40 x 6,0 x 4,9	25,89
M	10x1,50	8,50	D 140 x 45 x 7,0 x 5,5	25,56
M	12x1,75	10,20	D 180 x 50 x 9,0 x 7,0	41,98
M	14x2,00	12,00	D 200 x 56 x 11,0 x 9,0	48,91
M	16x2,00	14,00	D 200 x 63 x 12,0 x 9,0	60,56
M	18x2,50	15,50	D 220 x 63 x 14,0 x 11,0	81,47
M	20x2,50	17,50	D 250 x 70 x 16,0 x 12,0	108,44
M	22x2,50	19,50	D 280 x 80 x 18,0 x 14,5	133,05
M	24x3,00	21,00	D 280 x 80 x 18,0 x 14,5	181,02

* Mango cilíndrico





power coil
by celisa

INSERTOS PARA LA REPARACIÓN Y FORTALECIMIENTO DE ROSCAS



LA SOLUCIÓN AL ROSCADO DE PRECISIÓN

Repare roscas en 4 pasos



- 1
- 2
- 3
- 4

MACHOS DE MÁQUINA HSSCo TOLERANCIAS ESPECIALES Y SOBREMEDIDAS

		M2R4H	M4R4H	M2R6G	M4R6G	M2R7G	M4R7G	M2R+0,1	M4R+0,1	M2R+0,2	M4R+0,2	
TOLERANCIA		TOL 4H	TOL 4H	TOL 6G	TOL 6G	TOL 7G	TOL 7G	TOL 6H (+0,1)	TOL 6H (+0,1)	TOL 6H (+0,2)	TOL 6H (+0,2)	
MATERIAL		HSSCo 5%	HSSCo 5%	HSSCo 5%	HSSCo 5%	HSSCo 5%	HSSCo 5%	HSSCo 5%	HSSCo 5%	HSSCo 5%	HSSCo 5%	
ACABADO		BRILLANTE	BRILLANTE	BRILLANTE	BRILLANTE	BRILLANTE	BRILLANTE	BRILLANTE	BRILLANTE	BRILLANTE	BRILLANTE	
FORMA		FORMA B	FORMA B 35°	FORMA B	FORMA B 35°	FORMA B	FORMA B 35°	FORMA B	FORMA B 35°	FORMA B	FORMA B 35°	
		L ₁ x L ₂ x D ₂ x \square mm		€	€	€	€	€	€	€	€	
M 3x0,50	2,75	R 56x11x 3,5x 2,7	18,68	23,10	14,39	17,12	18,68	23,10	19,28	25,24	21,71	26,88
M 4x0,70	3,65	R 63x13x 4,5x 3,4	19,11	23,10	14,39	17,12	19,11	23,10	19,74	25,24	22,21	26,88
M 5x0,80	4,60	R 70x16x 6,0x 4,9	19,11	22,13	14,39	16,80	19,11	22,13	19,74	24,18	22,21	25,74
M 6x1,00	5,50	R 80x17x 6,0x 4,9	21,01	24,29	15,49	18,45	21,01	24,29	21,67	26,53	24,41	28,25
M 8x1,00	7,00	D 90x20x 6,0x 4,9			30,17	33,37						
M 8x1,25	7,40	R 90x20x 8,0x 6,2	23,52	27,73	18,01	21,62	23,52	27,73	24,29	30,28	27,35	32,25
M 10x1,00	9,00	D 90x16x 7,0x 5,5			35,63	41,47						
M 10x1,50	9,30	R 100x22x10,0x 8,0	28,92	32,91	22,16	24,74	28,92	32,91	29,87	35,91	33,65	38,23
MANGO DELGADO		M2D4H	M4D4H	M2D6G	M4D6G	M2D7G	M4D7G	M2D+0,1	M4D+0,1	M2D+0,2	M4D+0,2	
M 12x1,50	10,50	D 100x22x 9,0x 7,0		64,92	76,97							
M 12x1,75	11,20	D 110x24x 9,0x 7,0	37,30	44,28	29,23	35,21	37,30	44,28	37,41	47,43	42,51	50,51
M 14x2,00	13,05	D 110x26x11,0x 9,0			35,91	43,14			61,03	75,51	69,36	80,41
M 16x2,00	15,05	D 110x27x12,0x 9,0			44,38	52,10			71,79	91,25	81,60	97,17
M 18x2,50	16,80	D 125x30x14,0x11,0			62,58	64,51			108,54	122,89	115,58	130,86
M 20x2,50	18,80	D 140x32x16,0x12,0			64,63	74,14			117,29	130,77	124,89	139,25

4H.- Para roscas muy precisas. Ajuste más exacto.

6G.- Para roscas con recubrimientos. Espesores entre 20 - 40 μ

7G.- Para roscas con recubrimientos. Espesores entre 40 - 50 μ

6H. (+0,1)- Para obtener roscas con sobremedidas o para compensar deformaciones de tratamientos térmicos.

6H. (+0,2)- Para obtener roscas con sobremedidas o para compensar deformaciones de tratamientos térmicos.

PLAQUITAS PARA ROSCADO DE EXTERIORES

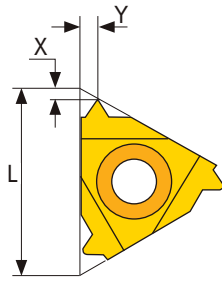

Rosca exterior a derechas RH

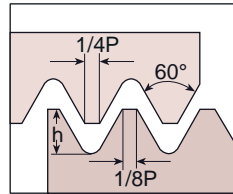
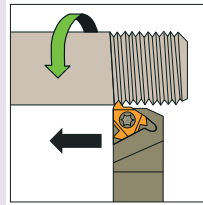

Norma: R262 (DIN 13)
Tolerancia clase: 6g/6H

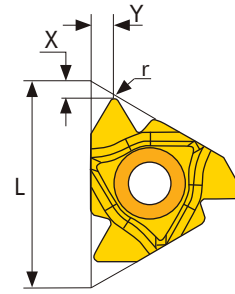

Perfil Total

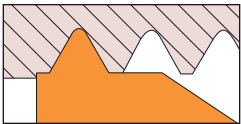

Perfil Parcial

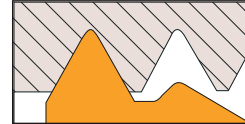

Rosca el perfil completo, terminando el diámetro exterior de la rosca. Utilizaremos una plaquita diferente para cada paso.

No termina el diámetro exterior de la rosca. La misma plaquita puede ser utilizada para una gama de diferentes pasos, que tengan el mismo ángulo de rosca.

PERFIL TOTAL 60°

ROSCADO EXTERIOR	L	PASO	h	X	Y	€
PRE-16-075	16	0,75	0,46	0,6	0,6	21,66
PRE-16-100		1,00	0,61	0,7	0,7	21,66
PRE-16-125		1,25	0,77	0,8	0,9	21,66
PRE-16-150		1,50	0,92	0,8	1	21,66
PRE-16-175		1,75	1,07	0,9	1,2	21,66
PRE-16-200		2,00	1,23	1	1,3	21,66
PRE-16-250		2,50	1,53	1,1	1,5	21,66
PRE-16-300		3,00	1,84	1,2	1,6	21,66

PERFIL PARCIAL 60°

ROSCADO EXTERIOR	L	RANGOS MÉTRICOS	RANGO PULGADAS	r	X	Y	€
PPRE-16-150	16	0,50-1,50	48 - 16	0,05	0,80	0,90	21,66
PPRE-16-300		1,75-3,00	14 - 8	0,27	1,20	1,70	21,66

PORTAHERRAMIENTAS DE ROSCADO DE EXTERIORES

ROSCADO EXTERIOR	H1=H=B=F	L1	L2	€
PEXT-20-16	20	128	30	138,74
PEXT-25-16	25	153	30	158,39

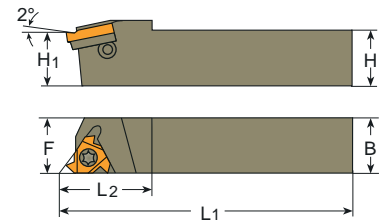

	Vc		Vc
ACERO BLANDO 70 kg/mm ² BC2	25 mm/min	ALUMINIO BC16	50 mm/min
ACERO TRATADO 120 kg/mm ² BC5	13 mm/min	TITANIO BC42	18 mm/min
INOXIDABLE BC50	11 mm/min	FUNDICIÓN BC7	25 mm/min
		LATÓN BC66	50 mm/min

FÓRMULA MATEMÁTICA PARA OBTENER LA VELOCIDAD DE GIRO DE LA PIEZA (RPM)

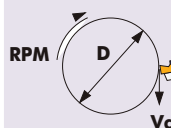

$$RPM = \frac{1000 \times Vc}{\pi \times D}$$

RPM: Revoluciones x minuto
Vc: Velocidad de Corte (m/min)
D: Diámetro Pieza (mm)

Las RPM-s se Obtienen en función de Vc y D

PLAQUITAS PARA ROSCADO DE INTERIORES

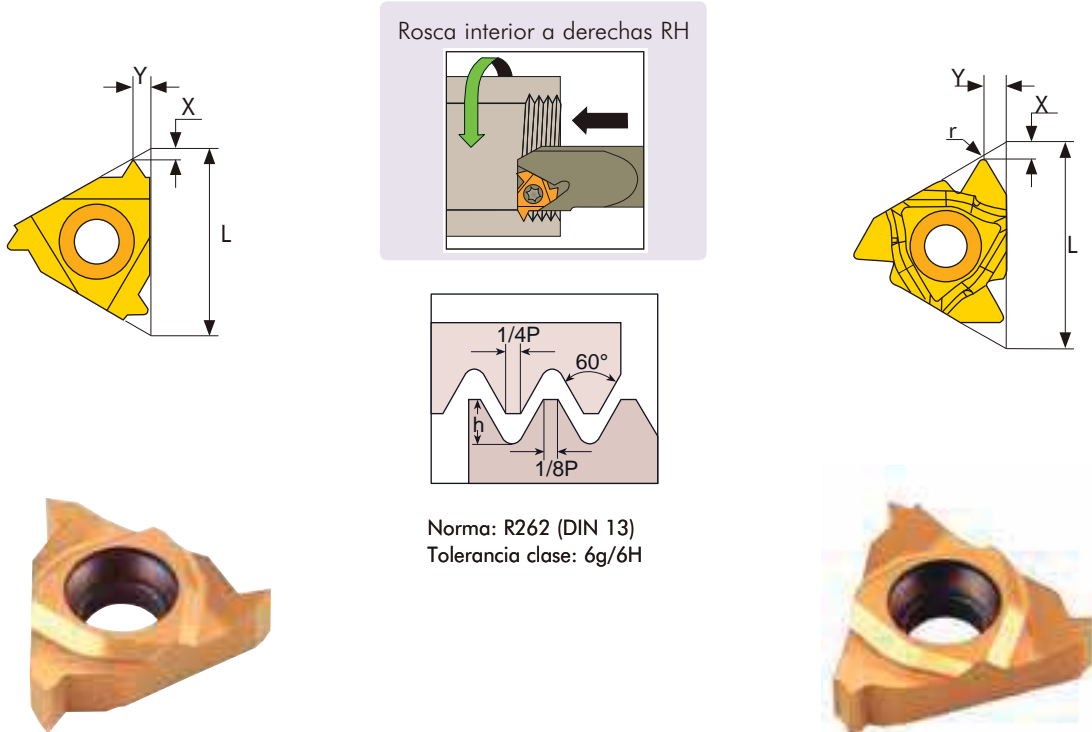

Norma: R262 (DIN 13)
Tolerancia clase: 6g/6H

PERFIL TOTAL 60°

ROSCADO INTERIOR	L	PASO	h	X	Y	€
PRI-16-075	16	0,75	0,43	0,6	0,6	21,66
PRI-16-100		1,00	0,58	0,6	0,7	21,66
PRI-16-125		1,25	0,72	0,8	0,9	21,66
PRI-16-150		1,50	0,87	0,8	1,0	21,66
PRI-16-175		1,75	1,01	0,9	1,2	21,66
PRI-16-200		2,00	1,15	1,0	1,3	21,66
PRI-16-250		2,50	1,44	1,1	1,5	21,66
PRI-16-300		3,00	1,73	1,1	1,5	21,66

PERFIL PARCIAL 60°

ROSCADO INTERIOR	L	RANGOS MÉTRICOS	RANGO PULGADAS	r	X	Y	€
PPRI-16-150	16	0,50-1,50	48 - 16	0,05	0,80	0,90	21,66
PPRI-16-300		1,75-3,00	14 - 8	0,16	1,20	1,70	21,66

PORTAHERRAMIENTAS DE ROSCADO DE INTERIORES

ROSCADO INTERIOR	L	L1	D	D1	A	∅ Mín. agujero	€
PINT-20-16	180	40	20	20	18	24	156,11
PINT-25-16	200	45	25	24,6	22,6	29	190,88

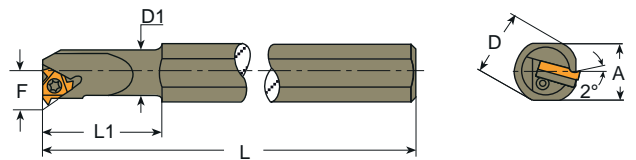

MACHOS DE MÁQUINA HSSCo EN ESTUCHES METÁLICOS

**USO
GENERAL**

**HSSCo
5%**



Ref. JM6



Ref. JM2





Ref. JM8



Ref. JM4

CONTENIDO

	FORMA C	FORMA B	 15°	 35°	 HSS	HSSCo 5% €
JM5	M3 - M4 - M5 - M6 M8 - M10 - M12	-	-	-	-	97,02
JM1	M3 - M4 - M5 - M6 M8 - M10 - M12	-	-	-	2.5 / 3.3 / 4.2 / 5.0 6.8 / 8.5 / 10.2 mm	116,04
JM6	-	M3 - M4 - M5 - M6 M8 - M10 - M12	-	-	-	103,37
JM2	-	M3 - M4 - M5 - M6 M8 - M10 - M12	-	-	2.5 / 3.3 / 4.2 / 5.0 6.8 / 8.5 / 10.2 mm	116,25
JM7	-	-	M3 - M4 - M5 - M6 M8 - M10 - M12	-	-	122,34
JM3	-	-	M3 - M4 - M5 - M6 M8 - M10 - M12	-	2.5 / 3.3 / 4.2 / 5.0 6.8 / 8.5 / 10.2 mm	146,18
JM8	-	-	-	M3 - M4 - M5 - M6 M8 - M10 - M12	-	124,45
JM4	-	-	-	M3 - M4 - M5 - M6 M8 - M10 - M12	2.5 / 3.3 / 4.2 / 5.0 6.8 / 8.5 / 10.2 mm	144,62

MACHOS DE MÁQUINA EN ESTUCHES METÁLICOS

Plus



Ref. JMPT2

CONTENIDO

	FORMA B	BRILLANTE	35°	BRILLANTE	HSSCo 5%	HSS PM		TiN
						€		€
JMP6	M3 - M4 - M5 - M6 M8 - M10 - M12		-		-	102,33	JMPT6	147,59
JMP2	M3 - M4 - M5 - M6 M8 - M10 - M12		-		2.5 / 3.3 / 4.2 / 5.0 6.8 / 8.5 / 10.2 mm	134,19	JMPT2	179,58
JMP8	-		M3 - M4 - M5 - M6 M8 - M10 - M12		-	147,59	JMPT8	162,55
JMP4	-		M3 - M4 - M5 - M6 M8 - M10 - M12		2.5 / 3.3 / 4.2 / 5.0 6.8 / 8.5 / 10.2 mm	179,58	JMPT4	194,64

INOX

CONTENIDO

	FORMA B	OX	35°	OX	HSSCo 5%	HSS PM		TiN
						€		€
JMX6	M3 - M4 - M5 - M6 M8 - M10 - M12		-		-	132,02	JMXT6	144,01
JMX2	M3 - M4 - M5 - M6 M8 - M10 - M12		-		2.5 / 3.3 / 4.2 / 5.0 6.8 / 8.5 / 10.2 mm	164,01	JMXT2	176,01
JMX8	-		M3 - M4 - M5 - M6 M8 - M10 - M12		-	150,66	JMXT8	166,09
JMX4	-		M3 - M4 - M5 - M6 M8 - M10 - M12		2.5 / 3.3 / 4.2 / 5.0 6.8 / 8.5 / 10.2 mm	182,64	JMXT4	198,07

1200
N/mm²

CONTENIDO

	FORMA B	OX	35°	OX	HSSCo 5%	HSS V3		TINALOX
						€		€
JMMD6	M3 - M4 - M5 - M6 M8 - M10 - M12		-		-	120,00	JMMDT6	170,37
JMMD2	M3 - M4 - M5 - M6 M8 - M10 - M12		-		2.5 / 3.3 / 4.2 / 5.0 6.8 / 8.5 / 10.2 mm	151,99	JMMDT2	202,35
JMMD8	-		M3 - M4 - M5 - M6 M8 - M10 - M12		-	136,95	JMMDT8	196,45
JMMD4	-		M3 - M4 - M5 - M6 M8 - M10 - M12		2.5 / 3.3 / 4.2 / 5.0 6.8 / 8.5 / 10.2 mm	168,94	JMMDT4	228,43

MACHOS DE MÁQUINA EN ESTUCHES METÁLICOS

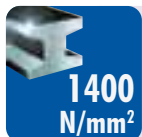

Ref. JMC2

CONTENIDO

	FORMA B	TiCN	15°	TiCN	HSSCo 5%	HSS-PM €
JMC6	M3 - M4 - M5 - M6 M8 - M10 - M12		-		-	204,14
JMC2	M3 - M4 - M5 - M6 M8 - M10 - M12		-		2.5 / 3.3 / 4.2 / 5.0 6.8 / 8.5 / 10.2 mm	236,13
JMC8	-		M3 - M4 - M5 - M6 M8 - M10 - M12		-	232,36
JMC4	-		M3 - M4 - M5 - M6 M8 - M10 - M12		2.5 / 3.3 / 4.2 / 5.0 6.8 / 8.5 / 10.2 mm	264,35



CONTENIDO

	FORMA B	TiN	35°	TiN	HSSCo 5%	HSSCo 5% €
JMD6	M3 - M4 - M5 - M6 M8 - M10 - M12		-		-	184,48
JMD2	M3 - M4 - M5 - M6 M8 - M10 - M12		-		2.5 / 3.3 / 4.2 / 5.0 6.8 / 8.5 / 10.2 mm	216,46
JMD8	-		M3 - M4 - M5 - M6 M8 - M10 - M12		-	208,03
JMD4	-		M3 - M4 - M5 - M6 M8 - M10 - M12		2.5 / 3.3 / 4.2 / 5.0 6.8 / 8.5 / 10.2 mm	240,02



CONTENIDO

	DIENTE ALTERNO	BRILLANTE	2 CANALES	BRILLANTE	HSS	HSSCo 5% €
JMAL6	M3 - M4 - M5 - M6 M8 - M10 - M12		-		-	146,06
JMAL2	M3 - M4 - M5 - M6 M8 - M10 - M12		-		2.5 / 3.3 / 4.2 / 5.0 6.8 / 8.5 / 10.2 mm	178,05
JMAL8	-		M3 - M4 - M5 - M6 M8 - M10 - M12		-	144,43
JMAL4	-		M3 - M4 - M5 - M6 M8 - M10 - M12		2.5 / 3.3 / 4.2 / 5.0 6.8 / 8.5 / 10.2 mm	176,42

MACHOS DE MÁQUINA EN ESTUCHES
**USO
GENERAL**
CONTENIDO

	FORMA B	BRILLANTE	35°	BRILLANTE	HSSCo 5% €
PT01	M4 - M5 - M6 M8 - M10		M4 - M5 - M6 M8 - M10		112,03



Ref. PT01

Plus
CONTENIDO

	FORMA B	BRILLANTE	35°	BRILLANTE	HSS PM €	TiN €
PT02	M4 - M5 - M6 M8 - M10		M4 - M5 - M6 M8 - M10		140,93	PT03 206,96



Ref. PT03

INOX
CONTENIDO

	FORMA B	OX	35°	OX	HSS PM €	TiN €
PT05	M4 - M5 - M6 M8 - M10		M4 - M5 - M6 M8 - M10		185,17	PT13 197,06



Ref. PT05

CONTENIDO

	FORMA B	OX	35°	OX	HSS V3 €	TINALOX €
PT04	M4 - M5 - M6 M8 - M10		M4 - M5 - M6 M8 - M10		158,92	PT14 238,82

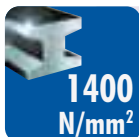

Ref. PT04

CONTENIDO

	FORMA B	TiCN	15°	TiCN	HSS PM €
PT11	M4 - M5 - M6 M8 - M10		M4 - M5 - M6 M8 - M10		287,90



Ref. PT11

MACHOS DE MÁQUINA EN ESTUCHES

AI



Ref. PT06

CONTENIDO

	DIENTE ALTERNO	2 CANALES	HSSCo 5%
			€
PT06	M4 - M5 - M6 M8 - M10	M4 - M5 - M6 M8 - M10	175,69

FUNDICIÓN



Ref. PT07

CONTENIDO

	FORMA C	HSSCo 5%
		€
PT07	M4 - M5 - M6 - M8 - M10 M4 - M5 - M6 - M8 - M10	132,78

LATÓN



Ref. PT10

CONTENIDO

	FORMA C	HSSCo 5%
		€
PT10	M4 - M5 - M6 - M8 - M10 M4 - M5 - M6 - M8 - M10	161,40

LAMINACIÓN



Ref. PT08

CONTENIDO

		HSSCo 5%
		€
PT08	M4 - M5 - M6 - M8 - M10 M4 - M5 - M6 - M8 - M10	243,01

AI



Ref. PT09

CONTENIDO

		HSSCo 5%
		€
PT09	M4 - M5 - M6 - M8 - M10 M4 - M5 - M6 - M8 - M10	327,38

TOL 6G



Ref. PT12

CONTENIDO

	FORMA B		HSSCo 5%
			€
PT12	M4 - M5 - M6 M8 - M10	M4 - M5 - M6 M8 - M10	181,54

EXPOSITORES DE METACRILATO PARA MACHOS DE MÁQUINA
EXPOSITOR DE METACRILATO
MM-03

Composición: Machos de máquina, Serie Normal

**HSSCo
5%**

**FORMA
B**

Agujeros pasantes, Ref. M2

M4	M5	M6	M8	M10	M12	M14
5	10	10	10	10	5	4



Agujeros ciegos, Ref. M4

M4	M5	M6	M8	M10	M12	M14
5	10	10	10	10	5	4

Dimensiones: ancho 240 x fondo 240 x alto 245 mm

1.484,84 €

Ref. MM-03



Ref. MM-04

EXPOSITOR DE METACRILATO
MM-04

 Composición: Machos de máquina, Serie Plus
 Fabricados en Acero sinterizado PM

**HSS
PM**
Plus
**FORMA
B**

Agujeros pasantes, Ref. M2

M4	M5	M6	M8	M10	M12	M14
5	10	10	10	10	5	4



Agujeros ciegos, Ref. M4

M4	M5	M6	M8	M10	M12	M14
5	10	10	10	10	5	4

Dimensiones: ancho 240 x fondo 240 x alto 245 mm

1.903,47 €
EXPOSITOR DE METACRILATO
MM-05

Composición: Machos de máquina para trabajos especiales

**FORMA
B**

Agujeros pasantes, Ref. M2



Agujeros ciegos, Ref. M4



M4	M5	M6	M8	M10	M12	M14
1	2	2	2	2	1	1



M4	M5	M6	M8	M10	M12	M14
1	2	2	2	2	1	1



M4	M5	M6	M8	M10	M12	M14
1	2	2	2	2	1	1



M4	M5	M6	M8	M10	M12	M14
1	2	2	2	2	1	1



M4	M5	M6	M8	M10	M12	M14
1	2	2	2	2	1	1



M4	M5	M6	M8	M10	M12	M14
1	2	2	2	2	1	1



M4	M5	M6	M8	M10	M12	M14
1	2	2	2	2	1	1



M4	M5	M6	M8	M10	M12	M14
1	2	2	2	2	1	1



M4	M5	M6	M8	M10	M12
1	2	2	2	2	1



M4	M5	M6	M8	M10	M12
1	2	2	2	2	1

Dimensiones: ancho 240 x fondo 240 x alto 245 mm

2.474,16 €

TERRAJA ROSCADORA PARA ROSCAR TUBO DE ACERO O PLÁSTICO DE PASO MÉTRICO

LEVOT

CARACTERÍSTICAS:

- * Esta terraja está pensada para roscar las cuatro medidas más pequeñas y más usuales de paso métrico: M16 x 1,50 - M20 x 1,50 - M25 x 1,50 - M32 x 1,50
- * Se recomienda el uso de aceite lubricante **CUT MAGIC** para conseguir un mejor resultado y mayor facilidad al realizar la rosca con menor esfuerzo por la reducción de coeficiente de fricción.
- * Presentación en caja de cartón.

Ref. M4-A (La más usual)

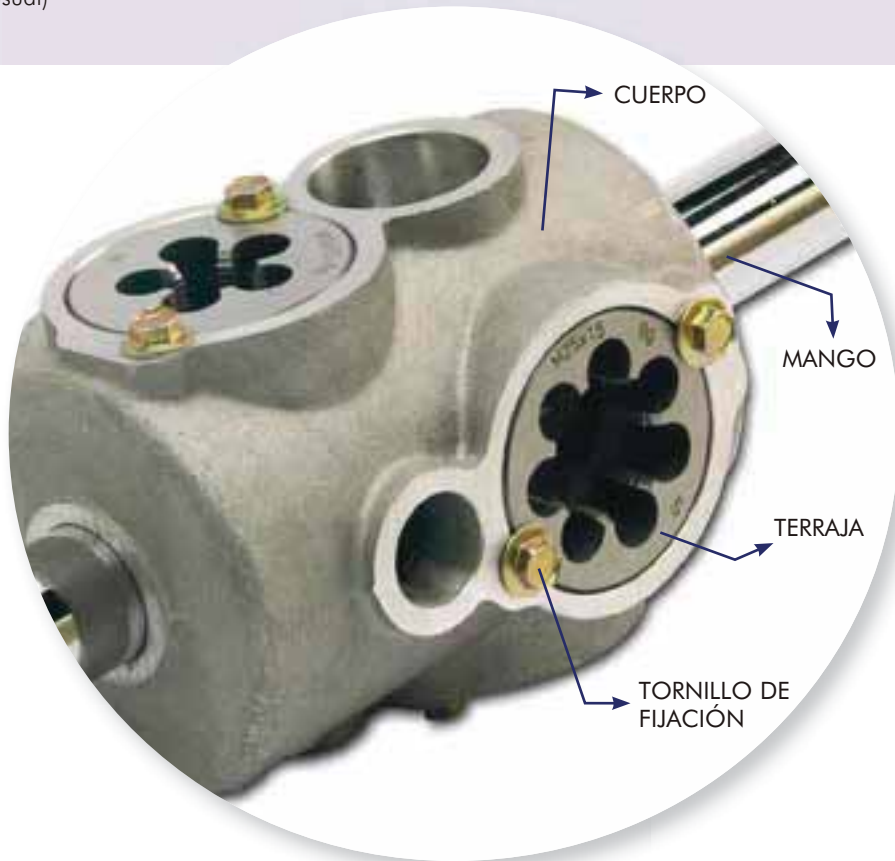

		MM4A
DESCRIPCIÓN		€
MM4A0001	Terraja completa LEVOT Ref. M4A: M16 - M20 - M25 - M32	674,90

RECAMBIOS PARA LAS TERRAJAS ROSCADORAS

Ref. M4-A

TOL
8g

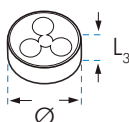

			MM
	DESCRIPCIÓN	Ø x L3 mm	€
MM4A1101M	Cuerpo mecanizado vacío M4A		260,26
MMCC0016	Cojinete LEVOT M16 x 1,50	50,5 x 16	68,25
MMCC0020	Cojinete LEVOT M20 x 1,50	50,5 x 16	71,66
MMCC0025	Cojinete LEVOT M25 x 1,50	50,5 x 16	103,91
MMCC0032	Cojinete LEVOT M32 x 1,50	50,5 x 16	140,28
MM4A1201	Mango M3 - A2 / M4 (Unidad)		58,98
MM4A1301	Tornillo de fijación (unidad)		8,43

TERRAJA ROSCADORA PARA ROSCAR TUBO DE ACERO O PLÁSTICO DE PASO MÉTRICO
LEVOT
CARACTERÍSTICAS:

- * La terraja Ref. MM3B0001, está pensada para roscar las tres medidas más grandes de paso métrico fino: M40 x 1,50 - M50 x 1,50 - M63 x 1,50 Presentación en estuche de plástico reforzado.
- * Las terrajas individuales Ref. MM3B0040-MM3B0050-MM3B0063 Se presentan en cajas de cartón.
- * Se recomienda el uso de aceite lubricante **CUT MAGIC** para conseguir un mejor resultado y mayor facilidad al realizar la rosca con menor esfuerzo por la reducción de coeficiente de fricción.

Ref. M3-B (para roscar M40 - M50 y M63 x 1,50)



		MM3B
DESCRIPCIÓN		€
MM3B0001	Terraja completa LEVOT Ref. M3-B: M40 - M50 - M63	1.155,33
MM3B0040	Terraja LEVOT Ref. M3-B, sólo con la terraja de M40 x 1,50	431,94
MM3B0050	Terraja LEVOT Ref. M3-B, sólo con la terraja de M50 x 1,50	498,96
MM3B0063	Terraja LEVOT Ref. M3-B, sólo con la terraja de M63 x 1,50	546,18

RECAMBIOS PARA LAS TERRAJAS ROSCADORAS

Ref. M3-B

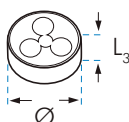
TOL
8g

			MM
	DESCRIPCIÓN	Ø x L3 mm	€
MMCC0040	Cojinete LEVOT M40 x 1,50	105 x 22	227,94
MMCC0050	Cojinete LEVOT M50 x 1,50	105 x 22	295,29
MMCC0063	Cojinete LEVOT M63 x 1,50	105 x 22	362,66
MM3B1201	Mango M3 - B (Unidad)		30,24
MM3B1301	Tornillo de fijación para la guía (Unidad)		1,48
MM3B1440	Guía M3-B para tubo de 40		26,20
MM3B1450	Guía M3-B para tubo de 50		27,53
MM3B1501	Tapa M3-B para la sujeción del cojinete		38,89